

<https://www.sunrisesr.com/>



三來司電子有限公司

精密焊接、點膠塗覆、自動鎖付、機器視覺自動化設備

自動化設備製造商



Add 東莞市常平鎮土塘長江墟路 1號華深科創園 2棟7樓
7th Floor, Building 2, Huashen Science and Technology Innovation
Park, No.1 Changjiang Xu Road, Tutang, Changping Town, Dongguan
City
Tel: 0769-82605595
Fax: 0769-82605596
Email: sr@sunrisesr.com
official website : www.sunrisesr.com

Add江蘇省蘇州市吳中區南湖路 51號1號樓
Building 1, No. 51 Nanhu Road, Wuzhong District,
Suzhou City, Jiangsu Province
Phone:0512-65644055
Fax:0512-67074539
Email:szs@sunrisesr.com
official website: www.sunrisesr.com

Add臺灣臺南市永康區華興街 162號
No. 162, Huaxing St., Yongkang Dist., Tainan
City, Taiwan
Tel:06-3124789
Fax: 06-3124789
Email:tw@sunrisesr.com
official website: www.sanlaisi.com

三來司電子有限公司

SANLAISI ELECTRONICS

- ◆ 東莞市三來司電子
Dongguan Sanlaisi Electronics Co., Ltd.
- ◆ 蘇州三來司電子
Suzhou Sanlaisi Electronics Co.,Ltd.
- ◆ 台灣三來司電子
Taiwan Sanlaisi Electronics Co., Ltd
- ◆ 官網: www.sunrisesr.com
Official website



公司簡介

COMPANY PROFILE

主力研發生產工業自動化設備及智能焊接工具，以旭升電子工具有限公司為本體，東莞為生產基地，並在蘇州及臺灣分設三來司電子有限公司，負責地區性的銷售及服務。

本公司投入大量優秀的專業技術人才，滿足客戶的生產需求為基礎，做到減少人力提高效率的工業要求，並依據實用、精密、耐久、節能、環保為導向，不斷研發創新，竭誠服務與客戶，已和國內外多家知名電子企業建立了良好的合作關係，以完善的售後服務，優越的品質，準時的交期，達到客戶最高的滿意。

公司主要產品：自動焊錫機、自動鎖付螺絲機、自動點膠機、自動氣剪機等，客制化及標準化之自動工業生產設備、無鉛高頻渦流發熱智能焊台、拔放台、破錫出錫系統、電批、氣批、離子風機等，及其周邊耗材設備為主，本公司將為您提供實物上的專業服務。

Our main focus is on the research and development of industrial automation equipment and intelligent welding tools, with Xusheng Electronic Tools Co., Ltd. as the main body and Dongguan as the production base. We also have established Sanlaisi Electronics Co., Ltd. in Suzhou and Taiwan, responsible for regional sales and services.

Our company has invested a large number of excellent professional and technical talents to meet the production needs of customers, achieving the industrial requirements of reducing manpower and improving efficiency. Guided by practicality, precision, durability, energy conservation, and environmental protection, we continuously research and develop innovation and wholeheartedly serve our customers. We have established good cooperative relationships with many well-known electronic enterprises at home and abroad, with perfect after-sales service, superior quality, and timely delivery, To achieve the highest customer satisfaction.

The main products of our company are: automatic soldering machine, automatic locking screw machine, automatic dispensing machine, automatic air shearing machine, etc., customized and standardized automatic industrial production equipment, lead-free high frequency solder station, rework station, solder wire feeder, electric screw driver, air screw driver, ion fan, etc., and its surrounding consumable equipment, the company will provide you with physical professional services.

部分客戶

SOME CUSTOMERS



公司資質與專利證書

COMPANY QUALIFICATION AND PATENT CERTIFICATE



主要設備展示

MAIN EQUIPMENT DISPLAY

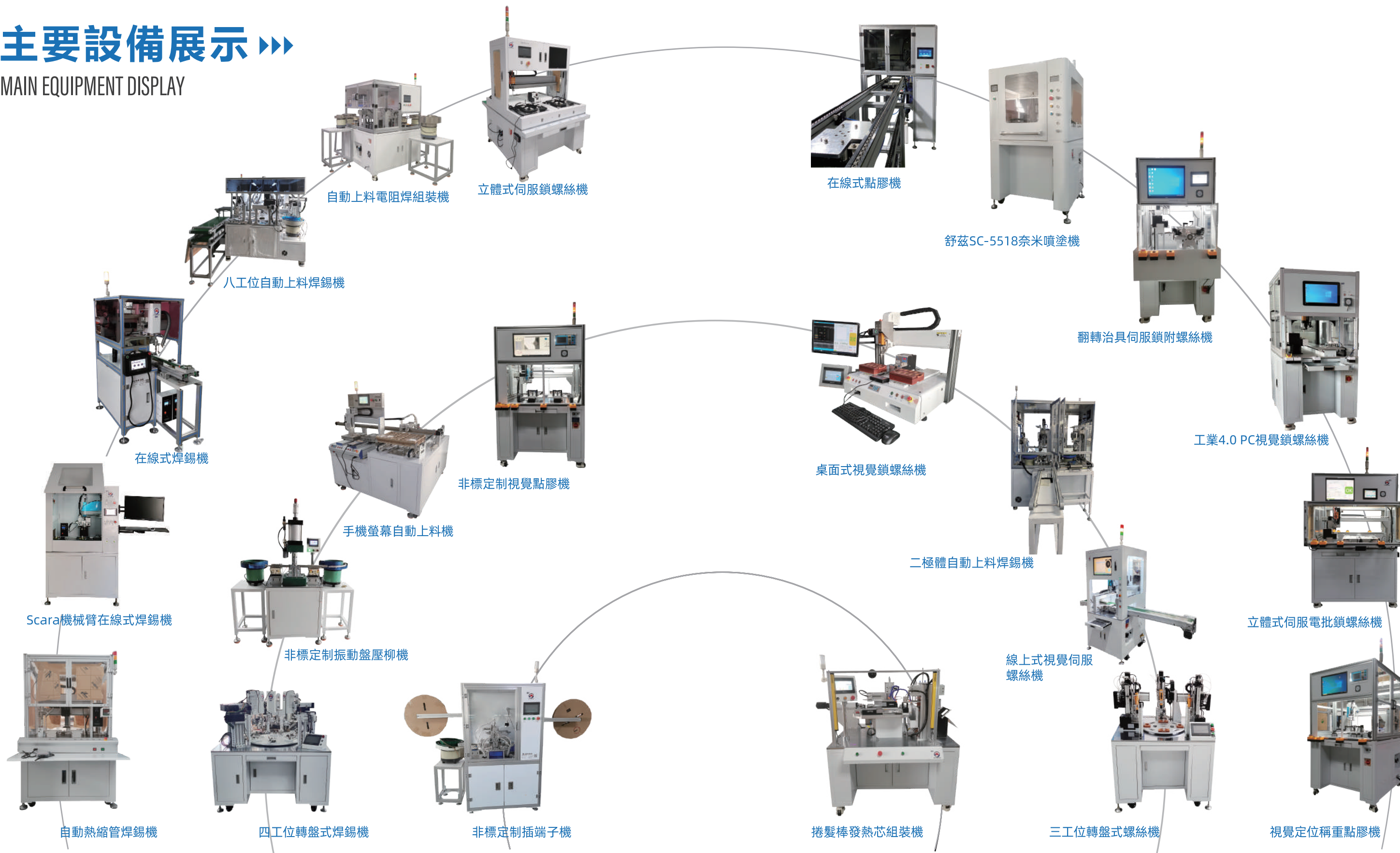

自動焊錫機

Automatic soldering machine

SR-轉盤式電阻焊組裝機

rotary resistance welding assembly machine

設備特點

Equipment Characteristics

- ◆ 非接觸焊接
- ◆ 電阻焊接
- ◆ 轉盤式運轉
- ◆ 轉盤式分料
- ◆ 自動上料下料
- ◆ Non-contact welding
- ◆ Resistance welding
- ◆ Rotary disk operation
- ◆ Rotary disc type parting
- ◆ Automatic feeding and unloading

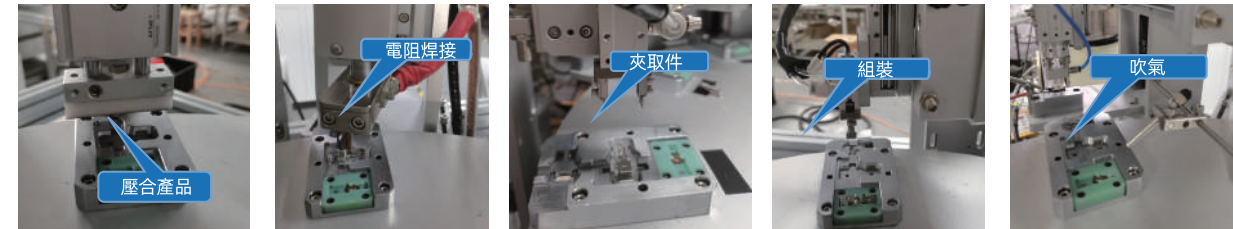

SR-四工位轉盤式焊錫機

Four-station rotating disk soldering machine

設備特點

Equipment Characteristics

- ◆ 視覺檢查不良產品
- ◆ 轉盤式運行
- ◆ 四工位同步焊錫
- ◆ 高頻渦流溫控焊接
- ◆ Visual inspection of defective products
- ◆ Rotary disk operation
- ◆ Four stations synchronous soldering
- ◆ High frequency eddy current temperature controlled welding

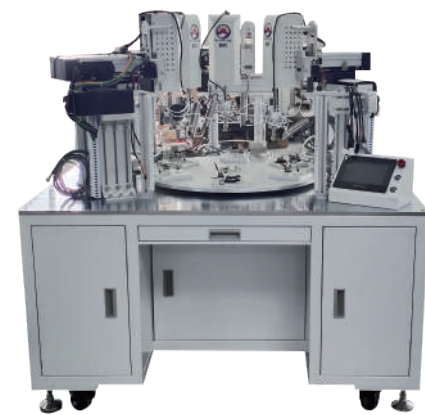

SR-五工位轉盤式焊錫機

Five station rotating disk soldering machine

設備特點

Equipment Characteristics

- ◆ 轉盤式自動焊錫
- ◆ 分料盤自動上料
- ◆ 流水線自動下料
- ◆ 工裝板自動迴流
- ◆ 五工位同步焊接
- ◆ 提高生產效率，保證焊錫質量一致
- ◆ 具有焊點，拖焊，壓焊和自動清潔烙鐵頭等功能
- ◆ 支持DXF圖紙導入功能
- ◆ 採用伺服電機+日本THK研磨絲桿，重複精度0.02MM

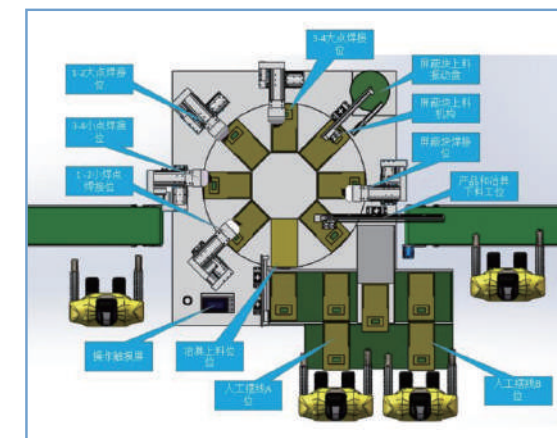

- ◆ Rotary disk automatic soldering
- ◆ Distributor plate automatically loading
- ◆ Automatic cutting of the line
- ◆ Automatic backflow of tooling plate
- ◆ Five station synchronous welding
- ◆ Improve production efficiency and ensure the consistency of solder quality
- ◆ It has the functions of spot welding, dragwelding, pressure welding and automatic cleaning of the soldering head
- ◆ Support DXF drawing import function
- ◆ Servo motor+Japanese THK grinding
- ◆ screw rod with repetition accuracy of 0.02mm

自動焊錫機

Automatic soldering machine

SR-在線式視覺 機械手焊錫機

SR-On-line visual manipulator soldering machine

產品優勢

Product advantage

- ◆提高生產效率，保證焊錫質量一致性；
- ◆具有點焊，拖焊，壓焊和自動清潔烙鐵頭等功能；
- ◆支持DXF 圖紙導入功能；
- ◆採用伺服電機+日本THK 研磨絲杆，重複精度0.02mm。



Scara焊錫機

三軸模組焊錫機



- ◆Improve production efficiency and ensure the consistency of solder quality;
- ◆It has the functions of spot welding, drag welding, pressure welding and automatic cleaning of welding head;
- ◆Support DXF drawing import function;
- ◆Servo motor and Japanese THK grinding screw are used, and the repeatability is 0.02 mm.



帶報警破錫機
Tin breaker with alarm



250W溫控焊台
Temperature controlled
welding table



911G手柄
911G handle

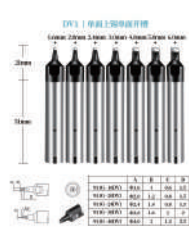

911GDV1烙鐵頭
911GDV1 Soldering tip



清洗盒
Purge box



烙鐵組件
Soldering iron
assembly

SR-防護罩款雙工位焊錫機

Three-dimensional double-station double-head soldering machine

產品優勢

Product advantage

- ◆雙頭同時焊接，提高效率含有安全防護罩員工操作安全高；
- ◆雙工位單頭焊錫效率高，具有點焊、拖焊、弧焊、斜焊、抖焊等功能；
- ◆自動出錫大功率焊接，焊點均勻，無鉛環保，效率翻倍；
- ◆手持編程器，設置存儲無限個運行路徑，隨時切換生產產品，無縫銜接；
- ◆模擬人工的各種焊接手法，代替作業人員，不在為培養焊手發愁。

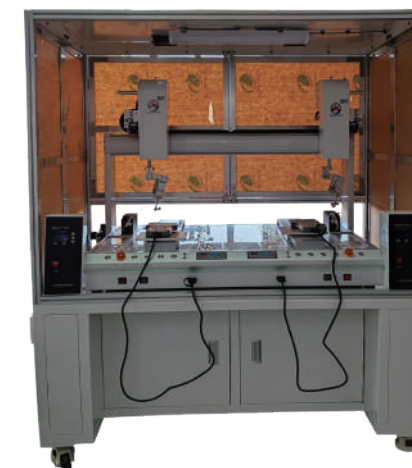

- ◆Double head welding at the same time, improve efficiency containing safety cover staff safe operation;
- ◆Double station single-head soldering efficiency is high, with spot welding, drag welding, arc welding, oblique welding, shake welding and other functions;
- ◆Automatic high-power soldering, solder joint uniform, lead-free environmental protection, efficiency doubled;
- ◆Handheld programmer, set storage unlimited running paths, switch production products at any time, seamless;
- ◆Simulate a variety of artificial welding techniques, instead of operators, no longer worry about training welding hands.

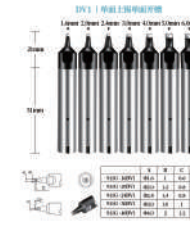

911GDV1烙鐵頭
911GDV1 Soldering tip



自動出錫破錫機
Automatic tin
breaking machine



清洗盒
Purge box



250W溫控焊台
Temperature controlled
welding table



911G手柄
911G handle



烙鐵組件
Soldering iron
assembly

自動焊錫機▶▶

Automatic soldering machine

SR-背靠背焊錫機

Back-to-back soldering machine

產品優勢

Product advantage

- ◆本機型採用背靠背模式，靈活、效率高，根據設定好的坐標，機器自動完成產品焊接，成倍的提高生產效率；
- ◆雙Y軸設計、交替作業，無取放產品時間實現一站式完成焊接和生產效率最大化；
- ◆焊錫系統：焊錫系統/國產；
- ◆破錫機：適用0.6--1.6錫絲；
- ◆送錫裝置：破錫送錫 可調線徑（可選斷錫堵錫報警功能）。
- ◆This machine adopts back-to-back mode, which is flexible and efficient. According to the set coordinates, the machine automatically completes product welding, which doubles the production efficiency;
- ◆Double Y-axis design, alternating operation, no time to take and put products, realizing one-stop welding and maximizing production efficiency;
- ◆Solder system: Solder system/domestic ;
- ◆Tin breaker: suitable for 0.6-1.6 tin wire;
- ◆Tin feeding device: adjustable wire diameter for breaking tin and sending tin (optional alarm function for breaking tin and blocking tin).

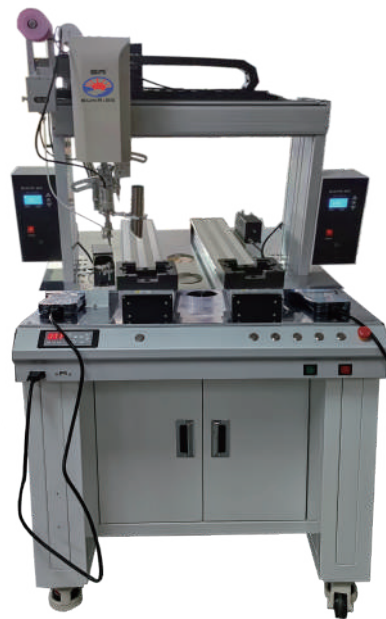

SR-鈹金自動焊錫機

Automatic sheet metal soldering machine

產品優勢

Product advantage

- ◆靈活多樣焊接方式，同時支持點焊拖焊；
- ◆JBC手柄烙鐵頭焊接，焊接速度快，高功率發熱錫台，參數複製功能。可存儲運動路徑，無限組，可設置存儲，隨時切換生產不同產品，靈活多變，更人性化。
- ◆Flexible and diverse welding methods, while supporting spot welding drag welding
- ◆JBC handle soldering iron head welding, welding speed, high power heating ; welding table, parameter replication function. Can store movement path, unlimited group, can set storage, at any time to switch production of different products, flexible, more user-friendly.



SR-立式雙滑台視覺焊錫機

SR-vertical double sliding table visual soldering machine

產品優勢

Product advantage

- ◆視覺定位焊接，CCD 視覺檢測產品；
- ◆360度錄影攝像可手機遠程監控機器運行；
- ◆設備密碼管控：工卡 (IC卡) 刷卡登錄，分級權限操作管理；
- ◆電阻式發熱原理，JBC一體式手柄焊接穩定高效率。
- ◆Visual positioning welding, CCD visual inspection products;
- ◆360-degree video camera can remotely monitor the operation of the machine by mobile phone;
- ◆Device password control: work card (IC card) swipes the card to log in, and hierarchical authority operation management;
- ◆Resistance heating principle, JBC integrated handle welding stability and high efficiency.



自動焊錫機

Automatic soldering machine

SR-自動焊錫熱縮管機

In-line soldering machine

設備資訊

Equipment information

- ◆ 焊接效率：2.5S/焊點，2.5S*2=5S/產品
 - ◆ 傳動方式：驅動電機/臺灣
 - ◆ 直線導軌：上銀/臺灣
 - ◆ 溫控：250瓦大功率溫控/三來司
 - ◆ 控制系統：三菱PLC+威倫通訊觸控螢幕/日本
 - ◆ 焊錫系統：焊錫系統/國產
 - ◆ 破錫機：適用0.6--1.6錫絲
 - ◆ 送錫裝置：破錫送錫 可調線徑（可選斷錫堵錫報警功能）
 - ◆ 外形尺寸：定制
 - ◆ 整機重量：200Kg
-
- ◆ Welding efficiency: 2.5S/ solder joint, 2.5S*2=5S/ product
 - ◆ Transmission mode: Drive motor/Taiwan
 - ◆ Linear guide rail: Shangyin/Taiwan
 - ◆ Temperature control: 250W high power temperature control/sanlaisi
 - ◆ Control system: Mitsubishi PLC + vinylon communication touch screen/Japan
 - ◆ Soldering system: Soldering system/domestic
 - ◆ Tin breaking machine: suitable for 0.6- 1.6 tin wire
 - ◆ Tin feeding device: Adjustable wire diameter of broken tin feeding (optional broken tin blocking tin alarm function)
 - ◆ Dimensions: Custom made
 - ◆ Weight: 200Kg



熱縮管加熱
Heat shrink tube heating

SR-懸臂式焊錫機

Cantilever type soldering machine

設備資訊

Equipment information

- ◆ 靈活多樣焊接方式，同時支持點焊拖焊；
 - ◆ 懸臂式焊錫機，可搭配流水線生產使用，無需機械手臂，即可實現流水線式自動焊錫工序；
 - ◆ 有焊點陳列複製，參數複製功能。可存儲運動路徑，無限組，可設置存儲，隨時切換生產不同產品，靈多變，更人性化。
-
- ◆ Flexible and diverse welding methods, while supporting spot welding drag welding;
 - ◆ Cantilever type soldering machine, can be used with the production line, without mechanical arm, can realize the automatic soldering process of the production line;
 - ◆ It has the functions of solder joint display copy and parameter copy. Can store the movement path, unlimited groups, can set the storage, and switch to produce different products at any time, which is flexible and more humanized.



01 意大利同步帶

高度耐磨，彈性好，內嵌鋼絲持久耐用

02 上銀導軌 絲杆

進口鋼材鑄造，精度高，超低噪音，耐磨性能強



03 明緯電源

台灣品牌、質量可靠、電壓輸出穩定、有短路保護 過載保護 過電壓保護/過熱保護。

自動焊錫機

Automatic soldering machine

SR-Hotbar熱壓焊接機

Hotbar hot press welding machine

產品優勢

Product advantage

- ◆高可靠性，在加壓的狀態下直到焊錫凝固，可以得到高信賴的沒有虛焊、浮起的焊接；
- ◆Hotbar焊接時對焊接物加壓的同時通電，利用加熱頭產生的焦耳熱對焊接物加熱焊接；
- ◆Hotbar焊接電源：提供焊接電流、溫度和時間設定，以及相關的程式設定；
- ◆外觀一致性，Hotbar焊接可以保證產品焊接的外觀一致性，無人工焊接的不規律性；
- ◆節省焊錫Hotbar只需要合適的錫量就可以保證可靠的焊接，避免人工浪費錫絲。

- ◆High reliability, in the state of pressure until the solder solidifies, you can get a high trust of no virtual welding, floating welding;
- ◆During Hotbar welding, the welding object is pressed and energized at the same time, and the welding object is heated and welded by using Joule heat generated by heating head;
- ◆Hotbar Welding Power Supply: Provides welding current, temperature and time Settings, as well as related program Settings;
- ◆Appearance consistency, Hotbar welding can ensure the appearance of product welding consistency, no manual welding irregularity;
- ◆Saving Solder Hotbar only requires the right amount of tin to ensure reliable welding and avoid manual waste of tin wire.



SR-多頭焊錫機

Multi-head soldering machine

產品優勢

Product advantage

- ◆多頭焊錫效率高，溫控焊接機頭超出溫差範圍，溫控報警、絲缺料或卡錫時報警；
- ◆可以選著雙頭或者四頭焊接，根據產品去定義適合用的焊錫機，也可以非標定制焊錫機；
- ◆自動出錫大功率焊接，焊點均勻，無鉛環保，效率翻倍；
- ◆精準的送錫減少焊絲的浪費，相比人工節約17%的錫絲。

- ◆Multi-head soldering efficiency is high, temperature control welding head beyond the temperature difference range, temperature control alarm, wire shortage or tin alarm;
- ◆You can choose two or four head welding, according to the product to define the suitable solder machine. Can also be customized non-standard soldering machine;
- ◆Automatic high-power soldering, solder joint uniform, lead-free environmental protection, efficiency doubled;
- ◆Precise tin feeding reduces wire waste, saving 17% tin wire compared to manual.

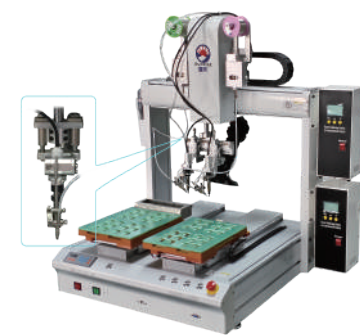
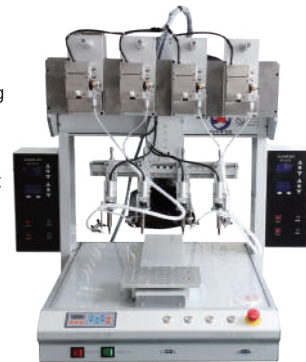

自動剪腳機

Automatic foot clipper

SR-自動氣剪機

Automatic air shears

適用行業

Applicable Industries

- ◆適用於管裝之功率晶體，三極管。
- ◆外型類似之電子零件也能適用。
- ◆用模具做不同形狀之變化。
- ◆抽換式模具，更換迅速容易。
- ◆操作及保養容易，不需太多訓練。
- ◆成型速度可無段式調速。
- ◆成型模具根據客戶要求定做。
- ◆成型模具及切刀均採用日本進口日本SKD-11材料製作。
- ◆加裝振動送料盤即可成型散裝零件。

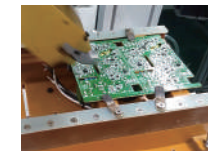

- ◆Suitable for power Fet, triode in tube.
- ◆Electronic parts with similar appearance can also be applied.
- ◆Use molds to make changes in different shapes.
- ◆Replaceable mold, quick and easy to replace.
- ◆Easy operation and maintenance, does not require much training.
- ◆The forming speed can be adjustable without stage.
- ◆Molding mold customized according to customer requirements.
- ◆Molding mold and cutter are made of SKD-11 materials imported from Japan.
- ◆Bulk parts can be formed by installing vibrating feeding tray.

SR-線上式氣剪機

in-line air shears

產品優勢

Product advantage

- ◆機帶吸氣裝置，可將剪下的PIN腳吸走（超過10MM長的不能吸走）；
- ◆到達紅外感應點，傳輸鏈暫停運輸，氣缸動作，固定產品，氣剪機開始運行。

- ◆The machine has a suction device, which can suck the cut PIN foot away (more than 10MM long can not suck away);
- ◆Reach the infrared sensing point, the transmission chain suspends the transport, the cylinder moves, the product is fixed, and the air shear machine starts to run.



自動剪腳機

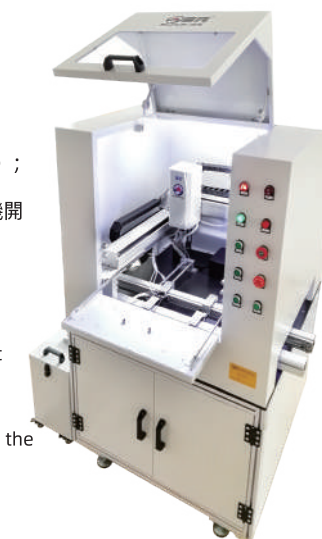

自動鎖螺絲機

Automatic screw locking machine

SR-立體式翻轉治具鎖螺絲機

fixture locking screw machine

產品優勢

Product advantage

- ◆設備密碼管控PC系統;
- ◆分級權限(作業員/工程師/管理員(廠商權限));
- ◆任何操作記錄/參數修改(均需要By每人工號記錄Log);
- ◆在管理員或工程師權限下,新卡首次刷卡時,提示確認註冊新卡權限(工程或作業員);
- ◆指定等級後,彈框綁定工號和姓名,確認後即完成註冊;
- ◆主介面下,註冊過的IC卡,可隨特刷卡切換帳戶;
- ◆工卡(IC卡)刷卡登錄後,題示當前工號/姓名,時間到達自動登出(鼠標不動計時,時間可設10~200秒);
- ◆工程(管理員)可進入主畫面/手動操作/參數設定/IE4.0/.../記錄報表...等任何界面;
- ◆作業登錄後只能在系統主介面軟體按鈕操作:運行/停止/復位,異常解除。



- ◆ Device password control PC system;
- ◆ Grading authority (operator/engineer/administrator (manufacturer authority));
- ◆ Any operation record/parameter modification (each manual number needs to be recorded By Log);
- ◆ Under the authority of the administrator or engineer, when the new card is swiped for the first time, it will be prompted to confirm the authority to register the new card (engineering or operator);
- ◆ After specifying the grade, the box is bound with the job number and name, and the registration is completed after confirmation;
- ◆ In the main interface, registered IC cards can be swiped with special cards to switch accounts;
- ◆ After the work card (IC card) swipes the card to log in, the current work number/name will be indicated, and the time will be automatically logged out (the time can be set to 10~200 seconds when the mouse does not move);
- ◆ Engineering (administrator) can enter any interface such as main screen/manual operation/parameter setting /IE4.0/.../ record report ...;
- ◆ After logging in, the operator can only press the button in the main interface software of the system: Run/Stop/Reset, and abnormal release.

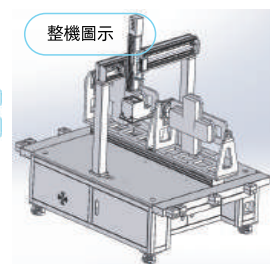
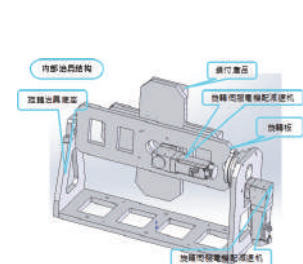

智能伺服電批
Intelligent servo batch



吸附式供料器
Adsorption feeder



一體式吸嘴
One piece suction nozzle

SR-立體式視覺智能電批鎖螺絲機

Three-dimensional flip fixture locking screw machine

產品優勢

Product advantage

- ◆具有浮高,滑牙,漏鎖等檢查報警功能;
- ◆單mark雙MARK圓孔定位多種演算法;
- ◆支持伺服電批轉速及扭力自主調節功能;
- ◆工作效率高:摒棄傳統式的每個螺絲孔拍照校準,一次鎖付完成,提高效率;
- ◆流水線作業,視覺掃描對孔位鎖緊螺絲,鎖附完成流動到下一步崗位中,高效率生產。



- ◆ It has the functions of checking and alarming such as floating height, slipping teeth and missing lock;
- ◆ Multiple algorithms for locating circular holes with single mark and double marks;
- ◆ Support the self-adjustment function of speed and torque of servo batch;
- ◆ High efficiency: Abandon the traditional photo calibration of each screw hole, and complete the lock payment at one time to improve efficiency;
- ◆ Assembly line operation, visual scanning of the hole position locking screw, lock the completion of the flow to the next post, high efficiency production.



360度攝像錄影手機
遠程監控
360-degree camera
recording and mobile
remote monitoring



設備密碼管控:
工卡 (IC卡) 刷卡登錄
Device password control:
worker card (IC card)
swipe card login

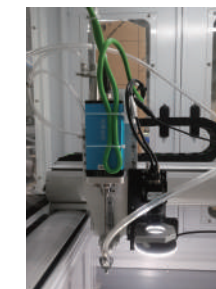

伺服智能電批
servo intelligent
E-screw driver

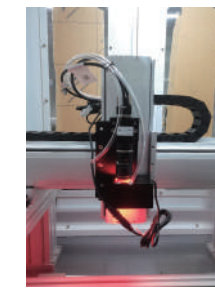

視覺定位鎖附
Visual positioning
lock with screws



一體式吸嘴
One piece
suction nozzle

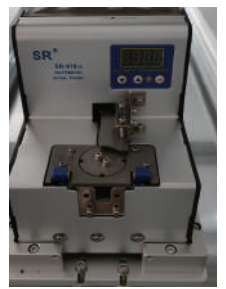

吸附式供料器
Adsorption feeder

自動鎖螺絲機 ▶▶

Automatic screw locking machine

SR-立式鏤空平台智能伺服螺絲機

Sr-vertical hollow platform intelligent servo screw machine

產品優勢

Product advantage

- ◆ 工具式快速換線(更換產品載具螺絲吸嘴);
- ◆ 磁吸式解決空間小(<0.3mm)深孔孔內鎖附避免刮蹭;
- ◆ 伺服智能電批參數監控上拋追溯;
- ◆ 鎖附圈數扭力及時確認浮鎖滑牙;
- ◆ 鏤空平台適合鎖附產品背麵有穿線類產品;
- ◆ 全自動鎖附螺絲, 自動掃碼功能。
- ◆ Tool type quick wire change (replacement of product carrier screw nozzle);
- ◆ Magnetic solution small space (<0.3mm) deep hole lock in the hole to avoid rubbing;
- ◆ Servo intelligent electric batch parameter monitoring upthrow tracing;
- ◆ Lock coil number torque timely confirm float lock slip teeth;
- ◆ Hollow platform is suitable for threading products on the back of lock attached products;
- ◆ Automatic locking screw, automatic code scanning function.

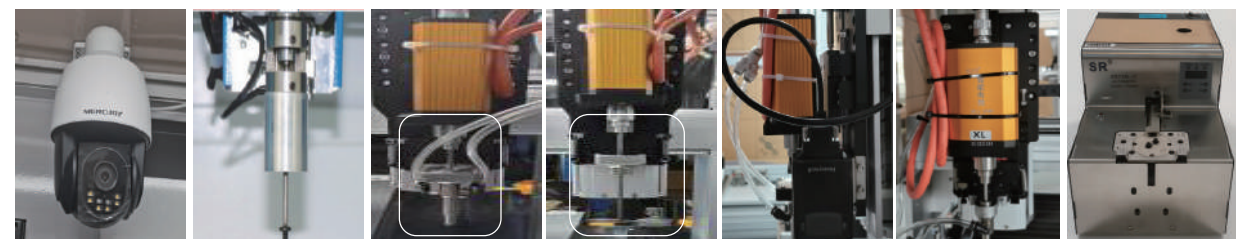

360度攝像錄影手機遠程監控 360-degree camera recording and mobile remote monitoring
 電磁磁(螺絲機專用) Electric magnetic (special for screw machine)
 真空吸嘴式 Vacuum nozzle type
 磁吸式批頭入孔 Magnetic head entry hole
 掃碼槍 Barcode scanner
 伺服智能電批 servo intelligent batc
 吸附式供料器 Adsorption feeder

SR-立體式吸氣式吹氣式螺絲機

Three-dimensional suction blowing screw machine

產品優勢

Product advantage

- ◆ 具有浮高, 滑牙, 漏鎖等檢查報警功能;
- ◆ 單mark 雙MARK圓孔定位多種算法;
- ◆ 支持伺服電批轉速及扭力自主調節功能;
- ◆ 工作效率高: 摒棄傳統式的每個螺絲孔拍照校準, 一次鎖付完成, 提高效率;
- ◆ 一款機器同時可以用吹氣式和吸氣式鎖附螺絲, 提高效率。



- ◆ It has the functions of checking and alarming such as floating height, slipping teeth and missing lock;
- ◆ Multiple algorithms for locating circular holes with single mark and double marks;
- ◆ Support the self-adjustment function of speed and torque of servo screw driver;
- ◆ High efficiency: Abandon the traditional photo calibration of each screw hole, and complete the lock payment at one time to improve efficiency;
- ◆ One machine can be attached with both blow and suction screws for increased efficiency.



360度攝像錄影手機遠程監控 360-degree camera recording and mobile remote monitoring
 設備密碼管控: 工卡 (IC卡) 刷卡登錄 Device password control: worker card (IC card) swipe card login
 伺服智能電批 servo intelligent batc
 視覺定位鎖附 Visual positioning lock with screws
 吸附式供料器 Adsorption feeder
 吹氣式供料器 Blowing feeder

自動鎖螺絲機 ▶▶

Automatic screw locking machine

SR-背靠背雙工位鎖螺絲機

SR- back-to-back double station screw locking machine

產品優勢

Product advantage

設備用途:

◆ 背靠背刮膠鎖螺絲機是一款能夠同時鎖螺絲和刮膠的自動化設備，採用獨特的背靠背設計，可以同時鎖螺絲和刮散熱膏，刮膠均勻，厚度可調，最薄可達0.2mm。

設備功能:

- ◆ 具有智能檢測功能，可檢測漏鎖、浮鎖、滑牙等；
- ◆ 靈活性強，標配萬用夾具適用多款機種的螺絲鎖付；
- ◆ 通用性強，更換螺絲輸送模組、吸嘴、批頭可適應M1.0-M4.0的螺絲鎖付；
- ◆ 設備外形小巧，可方便擺入生產線，標配前後取放功能，實現無人化操作；
- ◆ 雙Y軸設計、交替作業，無取放產品時間，同時可鎖付同一個產品中兩種不同螺絲，實現一站式完成鎖付和生產效率最大化。

Equipment use:

◆ Back-to-back glue scraping lock screw machine is an automatic equipment that can lock screws and scrape glue at the same time. It adopts a unique back-to-back design, which can lock screws and scrape heat dissipation paste at the same time, and scrape glue evenly, with adjustable thickness, and the thinnest can reach 0.2 mm.

Device functions:

- ◆ With intelligent detection function, it can detect missing lock, floating lock, sliding tooth, etc. Strong flexibility, universal fixture is standard, which is suitable for locking screws of various models;
- ◆ Strong versatility, replacing the screw conveying module, suction nozzle and batch head can adapt to the screw locking of M1.0-M4.0;
- ◆ The equipment is small in shape, which can be easily put into the production line, and the function of putting it before and taking it after is standard to realize unmanned operation;
- ◆ Double Y-axis design, alternating operation, no time to take and put products, and two different screws in the same product can be locked at the same time, realizing one-stop locking and maximizing production efficiency.



智能伺服電批
Intelligent servo batch



吸附式供料器
Adsorption feeder



一體式吸嘴
One piece suction



螺絲類型
Screw head type

SR-桌面式視覺掃碼版螺絲機

Sr-desktop visual scanning plate screw machine

產品優勢

Product advantage

- ◆ 如需工業4.0要求鎖附數據記錄保存，追溯對接MES可選擇PC控制版智能電批；
- ◆ 支持同時打兩種不一樣的螺絲（一個產品），智能伺服電批同時支付多任務參數；
- ◆ 可以兼併兩種工序打螺絲，（打完一種工序，停下來，再裝配件，再打一種工序螺絲）；
- ◆ 工作效率高：摒棄傳統式的每個螺絲孔拍照校準，一次鎖付完成，提高效率；
- ◆ 智能伺服電批，轉速快，精度高，低噪音，壽命長，免維護，扭力（0.3-9Kg.cm），轉速（0-3000轉）。



真空吸附式供螺釘方式



氣吹式供螺釘方式

- ◆ If industry 4.0 requires locking data record storage, traceability docking MES can choose the PC-controlled version of smart screw driver;
- ◆ Support to play two different screws (one product) at the same time, intelligent servo electric screw driver simultaneously pay multi-task parameters;
- ◆ Can merge two processes to play screws, (finish a process, stop, then assemble parts, and play a process screw);
- ◆ High efficiency: Abandon the traditional photo calibration of each screw hole, and complete the lock payment at one time to improve efficiency;
- ◆ Intelligent servo screw driver, fast speed, high precision, low noise, long life, maintenance-free, torque (0.3-9Kg.cm), speed (0-3000 RPM).



吹氣式供料器
Blowing feeder



掃碼二維碼功能
Qr code scanning function

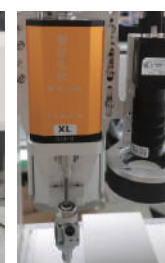

視覺定位鎖附
Visual positioning latch



吹氣式電批
Pneumatic electric screw driver



吸氣式電批掛件
Air-breathing electric batch pendant



吸附式供料器
Adsorption feeder

自動鎖螺絲機

Automatic screw locking machine

SR-雙電批普通伺服螺絲機

Sr-double electric batch general servo screw machine

產品優勢

Product advantage



- ◆如需工業4.0要求鎖付數據記錄保存，追溯對接MES 可選擇PC控制版智能電批；
- ◆支持同時打兩種不一樣的螺絲（一個產品），智能伺服電批同時支持三種不一樣的扭力；
- ◆可以兼併兩種工序打螺絲，（打完一種工序，停下來，再裝配件，再打一種工序螺絲）；
- ◆工作效率高：摒棄傳統式的每個螺絲孔拍照校準，一次鎖付完成，提高效率；
- ◆智能伺服電批，轉速快，精度高，低噪音，壽命長，免維護，扭力（0.3-9KGf.cm），轉速（0-3000轉）。

- ◆If Industry 4.0 requires the locking data to be recorded and saved, the retrospective docking MES can choose the PC control version intelligent screw driver;
- ◆Support two different screws (one product) at the same time, and intelligent servo screw driver supports three different torsion forces at the same time;
- ◆Can merge two processes to play screws, (finish a process, stop, then assemble parts, and play a process screw);
- ◆High efficiency: Abandon the traditional photo calibration of each screw hole, and complete the lock payment at one time to improve efficiency;
- ◆Intelligent servo screw driver, fast speed, high precision, low noise, long life, maintenance-free, torque (0.3-9KGf.cm), speed (0-3000 RPM).



一體式吸嘴
One piece suction nozzle

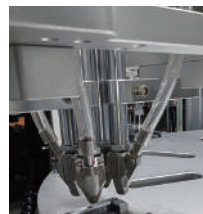

氣吹式夾嘴
Air blow clamp



一出二供料器
One out two feeder



一出一供料器
One feeder at a time



吹氣式電批
Pneumatic electric screw driver



吹氣式電批
Pneumatic electric screw driver

自動點膠機

Automatic dispensing machine

SR-手機螢幕自動上下料機

Mobile phone screen automatic loading and unloading machine

產品優勢

Product advantage

- ◆可以自動上下料，自動點膠，自動取放產品，左邊取放料流水線上，右邊取料滴膠，一步到位作業；
- ◆點膠效率為傳統點膠的8~10倍；
- ◆PC螢幕即時顯示檢測影像，觸控螢幕調試；快捷更高效，全自動點膠機，自動上下料，配合流水線高速生產；
- ◆上下取料一來一回速度6秒完成取料下料動作，一盤料10塊產品1分鐘左右完成。

- ◆It can automatically load and unload material, automatically dispense glue, automatically take and place the product, take and place the material on the left line, take and drop the glue on the right side, and work in one step;
- ◆Dispensing efficiency is 8 to 10 times that of traditional dispensing;
- ◆Real-time display of detection image on PC screen and debugging of touch screen; Faster and more efficient! All of automatic dispensing machine, since Move the loading and unloading, cooperate with the assembly line for high-speed production;
- ◆Take up and down the speed of 6 seconds to complete the action of taking down the material, a plate of 10 pieces of product about 1 minute to complete.



SR-捲髮棒發熱芯組裝機

Curling iron heating core assembly machine

產品優勢

Product advantage

- ◆捲髮棒組裝發熱芯機就是自動把發熱芯組裝一起；
- ◆杜絕了人工誤操作損傷產品，機器組裝輕鬆組裝好效率高；
- ◆可以做全自動感應器機器運行作業，也可以做成腳踏式開關控制操作機器；
- ◆機器光電感應觸發開機運行操作，人工只拿產品放好機器就自動運行組裝，轉盤式3工位效率高。

- ◆Curling iron assembly heating core machine is to automatically assemble the heating core together;
- ◆Eliminate manual misoperation damage products, machine assembly is easy to assemble high efficiency;
- ◆Can do automatic sensor machine operation, can also be made into a pedal switch control operation machine;
- ◆Machine photoelectric induction triggered startup operation. The manual just takes the product and puts it in the machine to run and assemble automatically. Rotary disk type 3 station efficiency is high .



自動點膠機

Automatic dispensing machine

SR-立體式視覺稱重點膠機

SR- stereoscopic vision weighing dispensing machine

產品優勢

Product advantage

- ◆設備管控：許可權註冊&刷卡登錄；
 - ◆視覺定位，點膠軌跡精準可控；
 - ◆設備具備稱重模組，可線上稱重，即時記錄並監控每個產品的點膠量；
 - ◆配備2D視覺檢測功能（膠水有無，膠寬等）；
 - ◆支持前進後出，後進前出等出料模式，且可搭載手臂上下料實現線上式。
- ◆Device control: Permission registration & Swipe card login;
 - ◆Visual positioning, accurate and controllable dispensing track;
 - ◆The equipment has a weighing module, which can be weighed online, record and monitor the dispensing amount of each product in real time;
 - ◆Equipped with 2D visual inspection function (glue, glue width, etc.);
 - ◆Support forward out, back in front out and other discharge mode, and can be equipped with arm loading and unloading to achieve online.



產品優勢

Product advantage

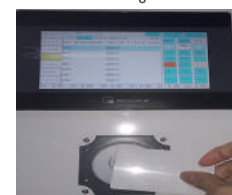

設備密碼管控：工卡（IC卡）刷卡登錄
Device password control: worker card



360度攝像錄影手機遠程監控
360-degree camera recording and mobile remote monitoring



測試膠水重量界面
Test the glue weight interface

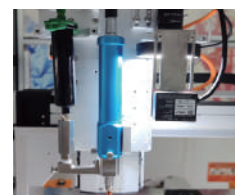

視覺點膠機
Visual lock dispensing machine

技術參數

Technical Parameter

型號	立體式視覺稱重點膠機	
工作行程	X軸500mm Y軸400mm Z軸100mm	
外形尺寸	800*750*1573（寬長高）	
圖形軌跡	點，直線，圓弧，整圓，曲線，多段線，螺旋線，橢圓，	
重複精度	±0.02mm	
位移速度	0-500mm/sec	
負載	Y/X軸負載	10kg
	Z軸負載	5kg
控制系統	工控機+運動控制卡 CCD視覺控制軟體+Win10系統	
點膠閥	壓電閥，氣動閥，螺桿閥，針閥等可選搭配	
轉動方式	導軌	台灣上銀直線導軌
	絲桿	日本THK研磨絲桿
	伺服電機	匯川伺服電機
氣源壓力	0.4-0.8MPa	
輸入電源	AC220V 50-60HZ 1.2KW	

SR-立體式視覺點膠機

Three-dimensional visual dispensing machine

適用行業

Applicable Industries

適用於手機[筆電]3C數位產品、汽車電子、電子元器件、LED、家用電器、醫療器械、新能源、LCD、SMT、RJ/ 網路變壓器、工業電子、工藝品、塑膠、金屬、玻璃和五金等行業的工藝。

Suitable for mobile phone [laptop] 3C digital products, automotive electronics, electronic components, LED, household appliances, medical devices, new energy, LCD, SMT, RJ/ network transformer, industrial electronics, handicrafts, plastics, metal, glass and hardware industries.

適應膠水面廣泛，如UV膠、環氧樹脂、矽膠，AB膠、黑膠、白膠、PU膠、瞬間膠、紅膠、錫膏、散熱膏、聚氨酯、油漆、酒精、墨水等。

It is suitable for a wide range of glue surfaces, such as UV glue, epoxy resin, silicone glue, AB glue, black glue, white glue, PU glue, instant glue, red glue and tin. Paste, cooling paste, polyurethane, paint, alcohol, ink, etc.



視覺點膠
Visual dispensing

SR-磁鋼片自動上料點膠機

Sr-magnetic steel sheet automatic feeding dispenser

產品優勢

Product advantage

- ◆高精度：精密雙面加工件，高強度，精度可達±0.02mm；
 - ◆點完取產品，按啟動自動上料擺放產品，自動點膠；
 - ◆高配功能：可選配鐳射測高，自動對針，自動清洗，自動稱重等功能；
 - ◆高靈活性：可搭配壓電閥，氣動閥，螺桿閥，噴霧閥，頂針閥等。
- ◆High precision: precision double-sided machined parts, high strength, accuracy up to 0.02 mm;
 - ◆After the product is clicked, the product is placed according to the start automatic loading and automatic dispensing;
 - ◆High matching function: laser height measurement, automatic needle alignment, automatic cleaning and automatic weighing can be selected. Yes;
 - ◆High flexibility: it can be matched with piezoelectric valve, pneumatic valve, screw valve, spray valve, top needle valve, etc.



螺旋點膠閥
Screw dispensing valve

自動點膠機

Automatic dispensing machine

SR-非標定制點膠機

Non-standard custom dispensing machine

適用行業

Applicable Industries

- ◆ 奈米噴塗機，加工不受限制，大尺寸或異形有死角位的產品照常可生產；
- ◆ 安裝：按照使用說明書將各部分裝合，安裝時注意各部分的安裝位置、塑膠噴霧器各連接部位不要旋得過緊，以免破裂；
- ◆ 噴霧：霧滴大小與壓力強度有關，可根據滅殺變相和環境調節噴頭進行噴灑。
- ◆ Nano spraying machine, processing is not limited, large size or special-shaped products with dead corners can be produced as usual;
- ◆ According to the installation: according to the instruction manual will be each part of the assembly, installation pay attention to the installation position of each part. The connecting parts of the plastic sprayer should not be turned too tightly to avoid rupture;
- ◆ Spray: the size of the droplets is related to the pressure strength, Spray can be carried out according to the kill phase and environmental regulation nozzle.

舒茲SC-5518奈米噴塗機



線上式CCD點膠機



奈米噴射閥
Nanojet valve



34A/B-D AB膠靜態雙液閥
rubber static double valve



AB膠動態雙液閥
AB rubber dynamic double liquid valve



溫控器
Temperature controller

- ◆ 高精度：精密雙面加工件，高強度，精度可達±0.02mm；
- ◆ 高速度：伺服電機+研磨絲杆+CCD視覺控制軟件；
- ◆ 高配功能：可選配激光測高，自動對針，自動清洗，自動稱重等功能；
- ◆ 高靈活性：可搭配壓電閥，氣動閥，螺桿閥，噴霧閥，頂針閥等。
- ◆ High precision: precision double-sided machined parts, high strength, accuracy up to 0.02 mm;
- ◆ High speed: servo motor+grinding screw +CCD visual control software;
- ◆ Matching function: laser height measurement, automatic needle alignment, automatic cleaning and automatic weighing can be selected;
- ◆ High flexibility: it can be matched with piezoelectric valve, pneumatic valve, screw valve, spray valve, top needle valve, etc.

SR-雙頭點膠機

Circular dispensing machine

產品優勢

Product advantage

適用膠水類型

- ◆ 一般常見的UV膠、silicon、EPOXY、紅膠、銀漿、AB膠、COB黑膠、導電膠、散熱鋁膏、瞬間膠、錫膏等點膠，皆可使用再在D系列設備上溫度恒定，出膠流暢；
- ◆ 三軸熱熔膠自動點膠機採用全膠桶加熱，能夠保證點膠頭的溫度均勻；而且點膠針頭也採用特殊製作，導熱性能好，可使各種膠體流暢出膠；它帶有針筒壓力調節設備，所以不會因氣壓等原因影響膠量，可使點膠工作持續穩定進行。

Applicable glue type

- ◆ Common UV glue, silicon, EPOXY, red glue, silver paste, AB glue, COB black glue, conductive glue, heat dissipation aluminum paste, instant glue, solder paste, etc. can all be used, and then the temperature is constant on D series equipment, and the glue is smooth;
- ◆ Three-axis hot melt adhesive automatic dispensing machine is heated by all plastic barrels, which can ensure the uniform temperature of the dispensing head; And point the glue needleThe head is also specially made, which has good thermal conductivity and can make all kinds of colloids flow out smoothly; It is provided with a syringe pressure regulating device, Equipment, so it will not affect the glue quantity due to air pressure and other reasons, so that the glue dispensing work can be carried out continuously and stably.



SR-三工位點膠機

three station dispensing machine

產品優勢

Product advantage

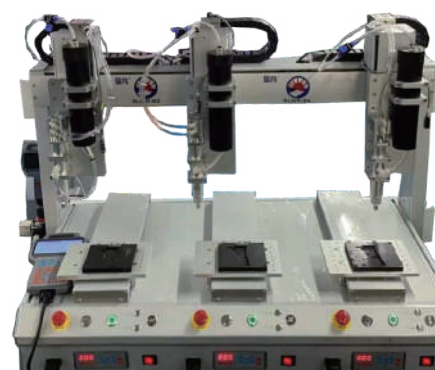

SR-60大流量氣缸閥
60 large flow cylinder valves

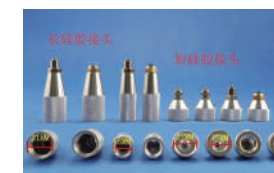

矽膠筒轉接頭
Silicone cylinder adapter



矽膠套筒
Silicone sleeve

自動點膠機

Automatic screw locking machine

SR-圓形點膠機

Circular dispensing machine

產品優勢

Product advantage

適用膠水類型

- ◆ 一般常見的UV膠、silicon、EPOXY、紅膠、銀漿、AB膠、COB黑膠、導電膠、散熱鋁膏、瞬間膠、錫膏等點膠，皆可使用再在D系列設備上點膠工作靈活；
- ◆ 該種熱熔膠自動點膠機的停膠時間、自動點膠時間以及點膠的速度、膠量大小等均可根據實際情況進行設定調節，點膠的工作靈活，各模式下都能夠保證穩定的出膠量，而且此種設備不存在膠液浪費等情況。

Applicable glue type

- ◆ Common UV glue, silicon, EPOXY, red glue, silver paste, AB glue, COB black glue, conductive adhesive and heat dissipation aluminum.Paste, instant glue, tin paste, etc. can be used, and then the D series is equipped with glue workers for spiritual work;
- ◆ This automatic dispensing machine for hot-melt glue can set a fixed adjusting section according to the actual situation, such as the stopping time, the self-moving dispensing time, the dispensing speed and the amount of glue, etc., and the dispensing workers can work flexibly, which can ensure the steady dispensing amount in all modes, and this kind of equipment does not exist in the situation of glue wave fee.



SR-自動點膠機

Automatic dispensing machine

產品優勢

Product advantage



技術參數

Technical Parameter

圖形軌跡	點，直線，圓弧，整圓，曲線，多段線，螺旋線，橢圓，	
重複精度	±0.02mm	
位移速度	0-500mm/sec	
負載	Y/X軸負載	10kg
	Z軸負載	5kg
控制系統	專業版點膠控制卡	
點膠閥	壓電閥，氣動閥，螺桿閥，針閥等可選搭配	
轉動方式	導軌	台灣上銀直線導軌
	絲桿	日本THK研磨絲桿
	伺服電機	匯川伺服電機
氣源壓力	0.4-0.8MPa	
輸入電源	AC220V 50-60HZ 1.2KW	

SR-點膠機壓合機

Dispensing machine pressing machine

產品優勢

Product advantage

適用膠水類型

- ◆ 一般常見的UV膠、silicon、EPOXY、紅膠、銀漿、AB膠、COB黑膠、導電膠、散熱鋁膏、瞬間膠、錫膏等點膠，皆可使用再在D系列設備上；
- ◆ 自動點膠完成再自動放壓合機壓合緊產品，高效率，大大提升效率；
- ◆ 點膠精度比人工要高很多，規律操作，避免人為因素出錯；
- ◆ 適用於一些產品點膠完後要壓合緊產品。

Applicable glue type

- ◆ Common UV glue, silicon, EPOXY, red glue, silver paste, AB glue, COB black glue, conductive glue, heat dissipation aluminum paste, instant glue, solder paste and other dispensing glue can all be used on D series equipment;
- ◆ Automatic glue dispensing is completed, and then the automatic pressing machine presses the product tightly, which is highly efficient and greatly improves the efficiency;
- ◆ The dispensing accuracy is much higher than that of manual operation, and the operation is regular to avoid human error;
- ◆ Suitable for some products to be pressed tightly after gluing.



SR-全自動UV點膠機

Fully automatic UV dispensing machine

產品優勢

Product advantage



技術參數

Technical Parameter

型號	全自動UV點膠機	
工作行程	X軸500mm Y軸400mm Z軸100mm	
外形尺寸	800*750*1573 (寬長高)	
圖形軌跡	點，直線，圓弧，整圓，曲線，多段線，螺旋線，橢圓，	
重複精度	±0.02mm	
位移速度	0-500mm/sec	
負載	Y/X軸負載	10kg
	Z軸負載	5kg
控制系統	專業版點膠控制卡	
點膠閥	壓電閥，氣動閥，螺桿閥，針閥等可選搭配	
轉動方式	導軌	台灣上銀直線導軌
	絲桿	日本THK研磨絲桿
	伺服電機	匯川伺服電機
氣源壓力	0.4-0.8MPa	
輸入電源	AC220V 50-60HZ 1.2KW	

自動壓鉚機

Automatic die casting machine

SR-非標振動盤壓鉚螺絲機

SR- nonstandard vibrating disk riveting screw machine

產品優勢

Product advantage

- ◆該設備是帶振動盤出料機構的自動壓鉚打螺絲裝置，包括自動送墊片產品、機座、打螺絲機、螺絲機頭、滑軌、氣缸固定板、氣缸；
- ◆還包括多出口振動盤出料機構，所述多出口振動盤出料機構包括料斗、底盤，料斗內壁設有螺旋上升的前進道，前進道末端設置有出料器，
- ◆自動將墊片送到需要鎖付的位置，再由鎖付機構用螺絲自動將產品與墊片鎖付好，效率高，安全快速方便，降低了勞動強度，提高了生產效率；
- ◆鉚壓機的夾緊裝置是機器的核心構件，用於夾緊鉚接的零件，保證鉚接的精度。其夾緊力可以通過液壓或電動來調節，一般以液壓方式調節為主；
- ◆控制系統是控制鉚壓機的核心系統，主要用於控制鉚壓機的運行。一般控制系統由智能控制器、感測器、PC機、觸控螢幕等組成，可以實現對鉚壓機的自動化控制；
- ◆移動裝置的作用是將鉚接的零件移動到設定的位置，以確保鉚接的準確性。一般情況下，移動裝置由伺服電機驅動，控制精度達到微米級別。



SR-非標振動盤壓鉚機

Non-standard vibrating disc press

產品優勢

Product advantage



- ◆This equipment is an automatic riveting and screwing device with vibrating plate discharging mechanism, including automatic gasket feeding products, machine base, screwing machine, screw head, slide rail, cylinder fixing plate and cylinder;
- ◆It also comprises a multi-outlet vibrating plate discharging mechanism, which comprises a hopper and a chassis, wherein the inner wall of the hopper is provided with a spiral ascending forward path, and the tail end of the forward path is provided with a discharger;
- ◆Automatically send the gasket to the position where it needs to be locked and paid, and then the locking and paying mechanism automatically locks the product and gasket with screws. Good, efficient, safe, fast and convenient, reducing labor intensity and improving production efficiency;
- ◆The clamping device of riveting press is the core component of the machine, which is used to clamp the riveted parts and ensure the riveting accuracy. Its clamping force can be adjusted by hydraulic or electric, and generally hydraulic adjustment is the main way;
- ◆The control system is the core system to control the riveting press, which is mainly used to control the operation of the riveting press. The general control system consists of intelligent controller, sensor, PC, touch screen and so on, which can realize the automatic control of riveting machine;
- ◆The function of the mobile device is to move the parts connected with crucian carp to the set position to ensure the accuracy of riveting. In general, the mobile device is driven by servo motor, and the control accuracy reaches micron level.

非標定制設備

Non-standard custom equipment

SR-自動測氣密貼標機

Non-standard automatic airtight machine

產品優勢

Product advantage

- ◆非標定制，測氣密機，貼防水標機；
- ◆機械手臂自動取料，人工放料；
- ◆自動測試產品氣密合不合格；
- ◆三工位同時工作運行，高效率；
- ◆全自動測試氣密貼防水標一體機。
- ◆Non-standard customization, measuring airtight machine, waterproof label machine;
- ◆Mechanical arm automatically take material, manual discharge material;
- ◆Automatic test product airtight is not qualified;
- ◆Three stations work at the same time, high efficiency;
- ◆Automatic test airtight waterproof label machine.

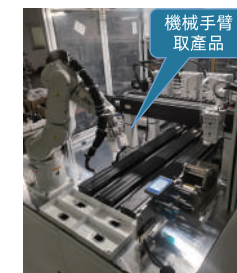

SR-貼標籤鎖附下壓機

Sr-label lock attached lower press

產品優勢

Product advantage

- ◆非標定制轉盤式，自動貼標籤；
- ◆自動鎖附，自動下壓產品機；
- ◆伺服智能電批參數監控上拋追溯；
- ◆鎖附圈數扭力即時確認浮鎖滑牙；
- ◆具有智慧檢測功能，可檢測漏鎖、浮鎖、滑牙等。
- ◆Non-standard custom rotary disk, automatic labeling;
- ◆Automatic locking, automatic pressing product machine;
- ◆Servo intelligent electric screw driver parameter monitoring upthrow tracing;
- ◆Confirm the floating lock sliding tooth immediately by the torque of the number of locking turns;
- ◆With intelligent detection function, it can detect missing locks, floating locks, slipping teeth, etc.



伺服電批
Servo screw driver

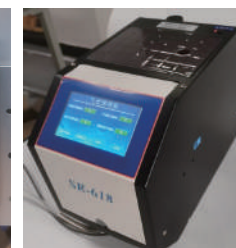

吹氣式供料器
Blowing feeder



非標定制設備

Non-standard custom equipment

SR-轉盤式點膠鎖附焊接機

Rotating disk solder spot lock lock

產品優勢

Product advantage

- ◆轉盤式點膠完成再鎖附螺絲，再焊接產品；
- ◆四個伺服電批同時鎖附產品；
- ◆單頭點膠，單頭焊接產品；
- ◆人工放料流水線，機械手自動取料，出料流水線，機械手下料；
- ◆自動點膠機一次性鎖付相同類型的產品成功率為98%以上，品質比手工點膠更好；
- ◆設備可以連續24小時作業，不受環境影響，不要擔心受到“用工荒”的影響。



- ◆Turntable dispensing is completed and then the screw is locked and the product is welded;
- ◆Four servo electric screw driver simultaneously lock attached products;
- ◆Single head dispensing, single head welding products;
- ◆Manual discharge line, manipulator automatic material, discharge line, mechanical hand material;
- ◆Automatic dispensing machine one-time lock the same type of product success rate is more than 98%, the quality is better than manual dispensing;
- ◆The equipment can work continuously for 24 hours, not affected by the environment, do not worry about the impact of "labor shortage".

設備概覽

Equipment overview

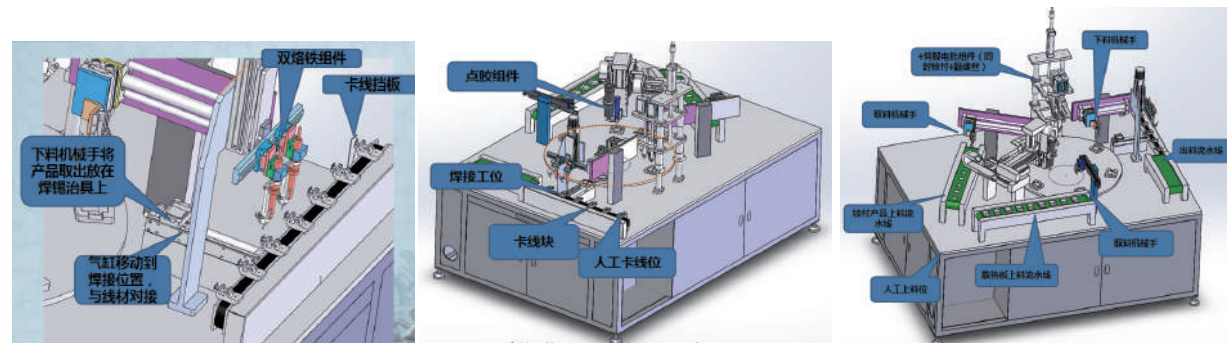

自動焊錫機

Automatic soldering machine

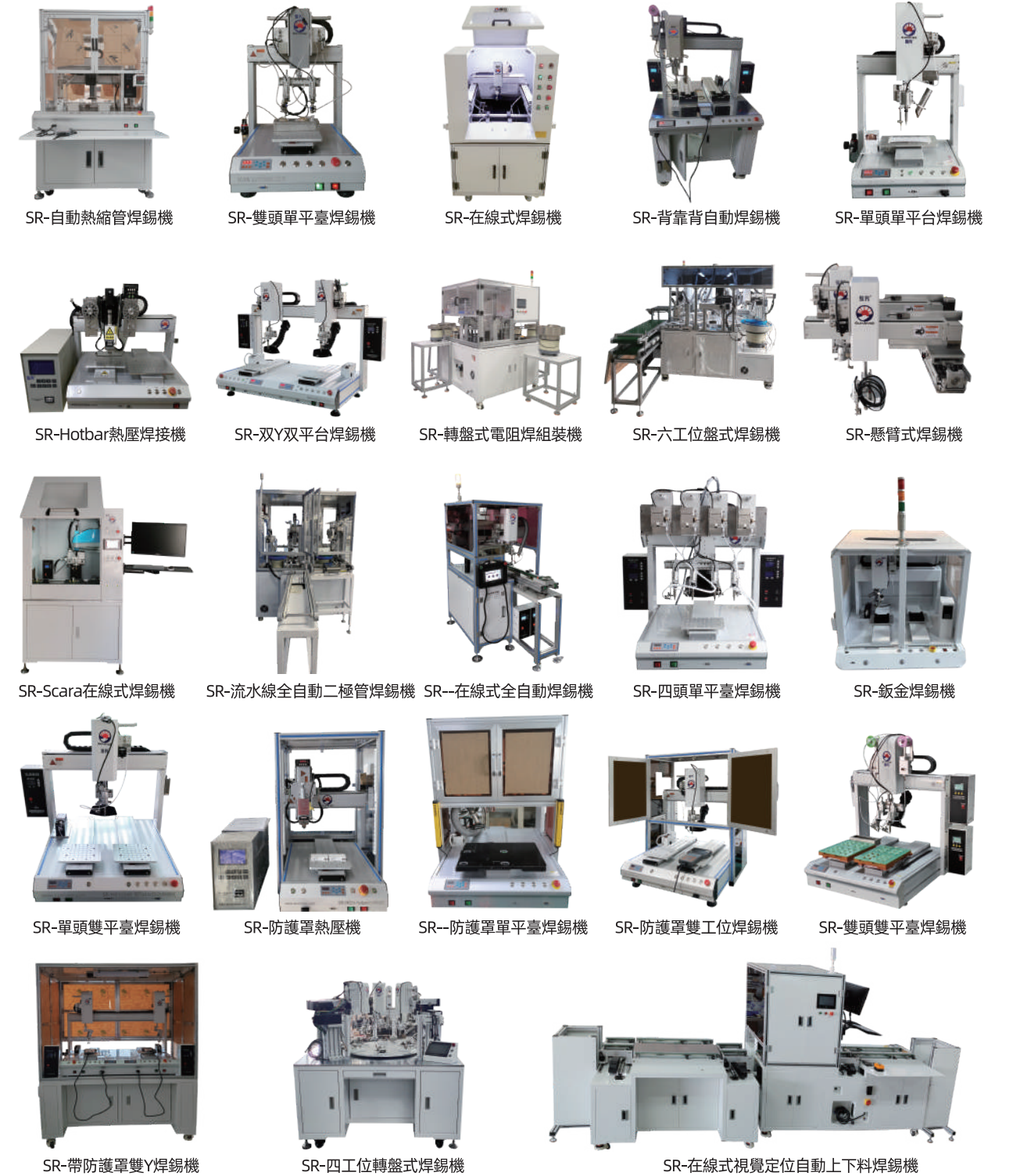

螺絲機設備

Screw machine equipment



SR-視覺鎖附螺絲機



SR-視覺鎖附掃碼螺絲機



SR-雙電批鎖附螺絲機



SR-三工位轉盤式螺絲機



SR-雙供料器伺服鎖螺絲機



SR-觸控螢幕鎖附螺絲機



SR-雙軸鎖螺絲機



SR-伺服電批鎖螺絲機

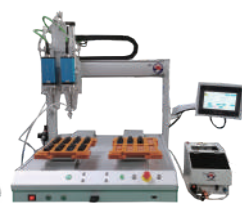

SR-雙伺服電批鎖螺絲機



SR-吹氣式螺絲機

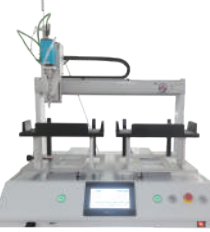

SR-觸控屏鎖螺絲機



SR-立體式伺服鎖附螺絲機



SR-立體式伺服鎖螺絲機



SR-空雙Tabel螺絲機



SR-吹氣式吸氣式螺絲機



SR-落地式單Tabel伺服螺絲機



SR-工業4.0 PC視覺鎖螺絲機



SR-雙Y翻轉治具鎖附螺絲機



SR-單Y翻轉治具鎖螺絲機



SR-在線式視覺定位鎖螺絲機



SR-自動下料螺絲機

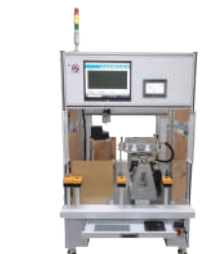

SR-翻轉治具螺絲機



SR-四工位轉盤式鎖螺絲機



SR-背靠背螺絲機

自動點膠機

Automatic dispensing machine



SR-磁鋼片自動上料點膠機



SR-點膠噴付焊接設備



SR-自動點膠壓合機



SR-點膠上料機



SR-氣缸式圓形點膠機定制款



SR-氣缸式圓形點膠機定制款



SR-單Z軸雙頭點膠機雙Y軸

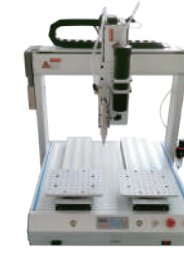

SR-自動點膠機



SR-氣缸式圓形點膠機定制款-雙組份膠水



SR-單頭點膠機



SR-單頭點膠機



SR-單工位雙頭點膠機



SR-視覺定位點膠機



SR-在線式視覺定位點膠機



SR-視覺定位稱重點膠機



SR-奈米點膠機



SR-振動盤電機機

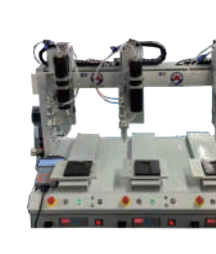

SR-三頭點膠機



SR-翻轉治具點膠機



SR-單工站點膠機



SR-雙頭點膠機



SR-AB膠頭點膠機

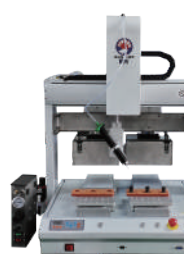

SR-雙工位UV點膠機



SR-單工位UV點膠機

焊錫機配件

Solder machine parts



SR-102T 破錫

- ◆ 步進電機出錫精準穩定
- ◆ 進口鎢鋼刀片經久耐用
- ◆ 內置導向輪防止錫線跑偏
- ◆ 錫線打孔防止錫珠飛濺
- ◆ 無錫報警
- ◆ 錫線適用範圍: 0.6-1.2mm
- ◆ The tin output of stepping motor is accurate and stable.
- ◆ Imported tungsten steel blades are durable.
- ◆ Built-in guide wheel prevents the tin wire from running off.
- ◆ Punching tin wire to prevent tin beads from splashing.
- ◆ no solder sire alarm
- ◆ Scope of application of tin wire: 0.6-1.2mm



SR-103 送錫

- ◆ 步進電機出錫精準穩定
- ◆ 內置導向輪防止錫線跑偏
- ◆ 大錫線專用
- ◆ 錫線適用範圍: 1.5-2.3mm
- ◆ Step motor tin discharge s accurate and stable
- ◆ Built in guide wheel to prevent deviation of tin wire
- ◆ Special for large tin wire
- ◆ Applicable range of tinwire:1.5-2.3mm



SR-102 送錫

- ◆ 步進電機出錫精準穩定
- ◆ 內置導向輪防止錫線跑偏
- ◆ 無錫報警
- ◆ 錫線適用範圍: 0.6-1.2mm
- ◆ The tin output of stepping motor is accurate and stable.
- ◆ Built-in guide wheel prevents the tin wire from running off.
- ◆ Wuxi alarm
- ◆ Scope of application of tin wire: 0.6-1.2mm



SR-四頭烙鐵組件

- ◆ 齒條調節更精準穩定
- ◆ 前後上下千分尺微調
- ◆ 彈簧緩衝, 防止傷板
- ◆ 送錫角度360度可調
- ◆ Rack adjustment is more accurate and stable.
- ◆ Fine-tune the front and rear micrometer.
- ◆ Spring buffering to prevent damage to the board.
- ◆ Tin feeding angle can be adjusted by 360 degrees.



SR-吹錫盒

- ◆ 氣吹式清潔烙鐵頭
- ◆ 抽屜式錫渣盒清理方便
- ◆ 定制電磁閥, 使用壽命長
- ◆ 外觀設計美觀使用壽命長
- ◆ Air-blown cleaning welding head
- ◆ Drawer tin slag box is easy to clean.
- ◆ Customized solenoid valve with long service life.
- ◆ Beautiful design and long service life.



SR-雙頭烙鐵組件

- ◆ 垂直傾斜可調
- ◆ 前後上下千分尺微調
- ◆ 彈簧緩衝, 防止傷板
- ◆ 送錫角度360度可調
- ◆ Vertical tilt is adjustable
- ◆ Fine-tune the front and rear micrometer.
- ◆ Spring buffering to prevent damage to the board.
- ◆ Tin feeding angle can be adjusted by 360 degrees.



SR-雙頭烙鐵組件

- ◆ 垂直傾斜可調
- ◆ 前後上下千分尺微調
- ◆ 彈簧緩衝, 防止傷板
- ◆ 送錫角度360度可調
- ◆ Vertical tilt is adjustable.
- ◆ Fine-tune the front and rear micrometer.
- ◆ Spring buffering to prevent damage to the board.
- ◆ Tin feeding angle can be adjusted by 360 degrees.



SR-單頭烙鐵組件

- ◆ 加寬導軌滑塊
- ◆ 角度靈活調節
- ◆ 緩衝彈簧, 防止傷板
- ◆ 送錫角度360度可調
- ◆ Widening guide rail slider
- ◆ Flexible angle adjustment
- ◆ Buffer spring to prevent board damage.
- ◆ Tin feeding angle can be adjusted by 360 degrees.

精密送錫器

Precision Tin Feeder



SR-101 送錫

- ◆ 步進電機出錫精準穩定
- ◆ 內置導向輪防止錫線跑偏
- ◆ 堵錫報警無錫報警
- ◆ 錫線適用範圍: 0.6-1.2mm
- ◆ The tin output of stepping motor is accurate and stable.
- ◆ Built-in guide wheel prevents the tin wire from running off.
- ◆ Tin blocking alarm no solder sire alarm
- ◆ Scope of application of tin wire: 0.6-1.2mm



SR-101T 破錫

- ◆ 步進電機出錫精準穩定
- ◆ 進口鎢鋼刀片經久耐用
- ◆ 內置導向輪防止錫線跑偏
- ◆ 錫線打孔防止錫珠飛濺
- ◆ 堵錫報警無錫報警
- ◆ 錫線適用範圍: 0.6-1.2mm
- ◆ The tin output of stepping motor is accurate and stable.
- ◆ Imported tungsten steel blades are durable.
- ◆ Built-in guide wheel prevents the tin wire from running off.
- ◆ Punching tin wire to prevent tin beads from splashing.
- ◆ Tin blocking alarm no solder sire alarm
- ◆ Scope of application of tin wire: 0.6-1.2mm



SR-102 送錫

- ◆ 步進電機出錫精準穩定
- ◆ 內置導向輪防止錫線跑偏
- ◆ 無錫報警
- ◆ 錫線適用範圍: 0.6-1.2mm
- ◆ The tin output of stepping motor is accurate and stable.
- ◆ Built-in guide wheel prevents the tin wire from running off.
- ◆ no solder sire alarm
- ◆ Scope of application of tin wire: 0.6-1.2mm



SR-201 破錫

- ◆ 步進電機出錫精準穩定
- ◆ 進口鎢鋼刀片經久耐用
- ◆ 錫線打孔防止錫珠飛濺
- ◆ 錫線適用範圍: 0.6-1.0mm
- ◆ The output of stepping motor is accurate and stable.
- ◆ Imported tungsten steel blades are durable.
- ◆ Stamp tin wires to prevent tin beads from splashing.
- ◆ Tin wire application range: 0.6-1.0mm.



SR-220 送錫

- ◆ 步進電機出錫精準穩定
- ◆ 內置導向輪防止錫線跑偏
- ◆ 堵錫報警無錫報警
- ◆ 錫線適用範圍: 0.6-1.2mm
- ◆ The tin output of stepping motor is accurate and stable.
- ◆ Built-in guide wheel prevents the tin wire from running off.
- ◆ Tin blocking alarm no solder sire alarm
- ◆ Scope of application of tin wire: 0.6-1.2mm



SR-220T 破錫

- ◆ 步進電機出錫精準穩定
- ◆ 內置導向輪防止錫線跑偏
- ◆ 錫線打孔防止錫珠飛濺
- ◆ 堵錫報警無錫報警
- ◆ 錫線適用範圍: 0.6-1.2mm
- ◆ The tin output of stepping motor is accurate and stable.
- ◆ Built-in guide wheel prevents the tin wire from running off.
- ◆ Punching tin wire can stop tin beads from splashing.
- ◆ Tin blocking alarm no solder sire alarm
- ◆ Scope of application of tin wire: 0.6-1.2mm

點膠閥選型▶▶

Dispensing valve selection



SR-AB膠動態雙液閥



SR-34A/B-D AB膠靜態雙液閥

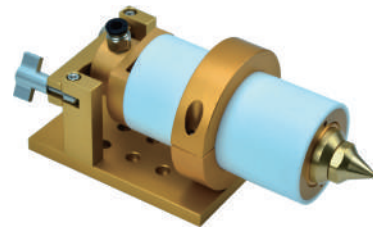

SR-56R PUR熱熔閥 (30CC)

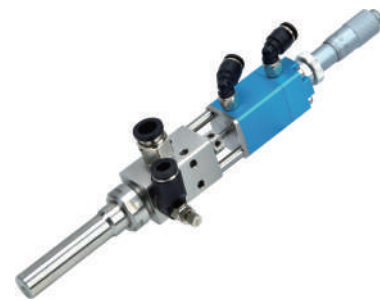

SR-21GP高頻噴霧閥



SR-21DP點狀噴霧閥

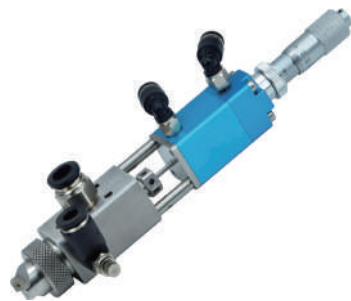

SR-SP扇形噴霧閥



SR-65ZL AB膠製冷截留閥 (風冷)



SR-72ZJ AB膠製冷截留閥 (水冷)



SR-75QZ雙組分AB膠氣動推膠製冷截流裝置(250ML)



SR-150SZJ伺服螺桿推膠製冷截流閥 (490ML)



SR-86QJ雙組分AB膠氣動推膠製冷截流裝置 (400ML)

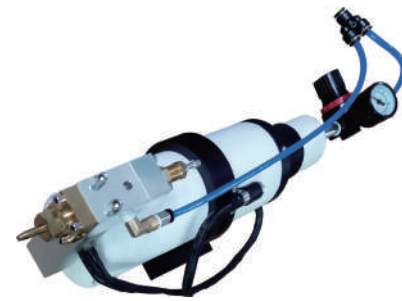

SR-98RZ PUR-熱熔點膠閥

點膠閥選型▶▶

Dispensing valve selection



SR-高速噴射閥



SR-高速噴射閥



SR-高頻高速噴射閥 (鎢鋼閥)

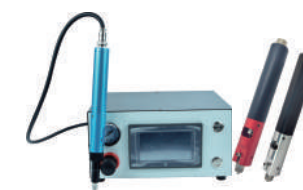

SR-精密螺桿閥



SR-25G砂膠閥



SR-16WD氣缸止閥



SR-21QP千分尺噴霧閥

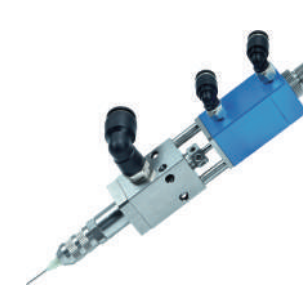

SR-21JH精密回吸閥



SR-26TH提升式回吸閥



SR-60HX回吸式一體點膠閥

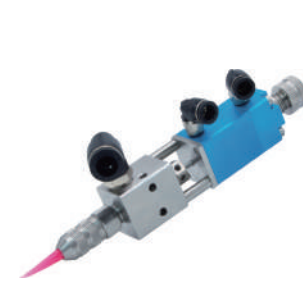

SR-21D頂針閥



SR-25YD小圓閥

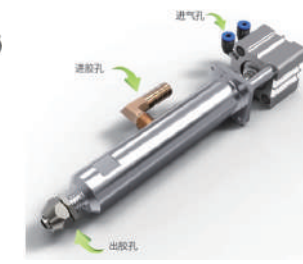

SR-60大流量氣缸閥



SR-3131H/HG-21H回吸閥

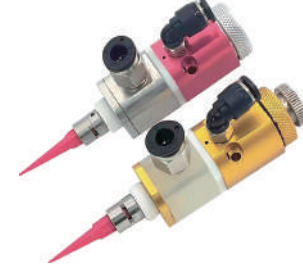

SR-25G隔膜閥

手持式螺絲機▶▶

Hand held screw machine

SR-618掌上型螺絲機

Non-standard vibrating disc press riveting screw machine

產品信息

product information

- ◆料盤規格: $\Phi 130$
- ◆電機: 毛刷驅動電機
- ◆定位精度: ± 0.02 mm
- ◆工作氣壓: 0.4~0.6Mpa
- ◆供料方式: 吹氣式
- ◆可搭配普通離合式電批, 或是智能伺服電批
- ◆設備功率: 0.15kW
- ◆外形尺寸: 280.5*165*242.5 (寬長高)
- ◆整機重量: 約10Kg

產品優勢與亮點分析

- 1、可以螺絲通用, 通過調節與更新小部件實現通用, 操作簡易可以快速實現更換;
- 2、氣源動力, 性能穩定, 一天可持續24小時工作, 壽命可達5-8年;
- 3、採用渦輪方式上料, 體積和噪音更小, 維護更方便, 可擺在工作臺上或台下, 節省空間;
- 4、0.5秒即可供一粒螺絲, 不用擔心鎖附過快, 螺絲供應不及時;
- 5、掌上型自動鎖螺絲機, 螺絲輸送, 鎖附一氣呵成, 再也不用收取螺絲了, 大大提高生產效率, 節省人工, 工作穩定, 不會卡料, 即時螺絲不良導致卡螺絲, 非專業人員也可容易排出故障;
- 6、開關部件選用高質量的合金鋼材料並經過特殊的熱處理, 各氣動、電氣元器件都選用進口原裝部件。



SR-掌上型螺絲機

SR-handheld screw machine

產品信息

product information

- ◆料盤規格: $\Phi 180$
- ◆電機: 毛刷驅動電機
- ◆定位精度: ± 0.02 mm
- ◆供料方式: 吹氣式
- ◆工作氣壓: 0.4~0.6Mpa
- ◆可搭配普通離合式電批, 或是智能伺服電批
- ◆設備功率: 0.15KW
- ◆外形尺寸: 387.5*256*261.5 (寬長高)
- ◆整機重量: 約15Kg

產品優勢與亮點分析

- 1、扭力精準並調節方便, 保證鎖緊品質;
- 2、0.5秒即可供一粒螺絲, 不用擔心鎖附過快, 螺絲供應不及時;
- 3、可配自動化平臺螺絲機用做供料送螺絲機, 或者掌上型拿著鎖附產品效率高;
- 4、可以螺絲通用, 通過調節與更新小部件實現通用, 操作簡易可以快速實現更換;
- 5、開關部件選用高質量的合金鋼材料並經過特殊的熱處理, 各氣動、電氣元器件都選用進口原裝部件;
- 6、方便快捷, 該機型外形美觀, 設計新穎, 小巧輕便, 放在臺上台下都可, 節省空間, 主要使用於電子、塑膠、玩具、電器、通訊設備等行業的裝配。



SR-301S-C供料器

Non-standard vibrating disc press riveting screw machine

產品信息

product information

- ◆品牌型號: 301S-C數顯型/三來司
- ◆輸入電壓: AC220V
- ◆輸出速度: 60-180pcs/分鐘
- ◆定位精度: ± 0.02 mm
- ◆適用螺絲: M1.7-M5.0可調(牙長19m)
- ◆螺絲分料方式: 滾動盤掃刷
- ◆附帶配件: 內六角扳手, 直流電源, 說明書
- ◆外形尺寸: 200.20*126*150.10 (寬長高)
- ◆整機重量: 3.1Kg

產品優勢與亮點分析

- 1、專門排列短小螺絲, 機器穩定自帶信號接線端子, 方便信號通訊;
- 2、體積小, 可配合產線作業, 降低工人的勞動強度;
- 3、通用性強, 更換螺絲輸送模組可適應 M 1.4- M 6的螺絲鎖付;
- 4、氣源動力, 性能穩定, 一天可持續24小時工作, 壽命可達5-8年;
- 5、安裝此機器要在一個水準、穩定且能夠承受機器重量和運行條件的位置上安裝;
- 6、當機器在操作過程中發現有異常現象, 譬如刺耳的聲音等, 請立即停止機器運行, 關掉電源開關, 切斷電源適配器;

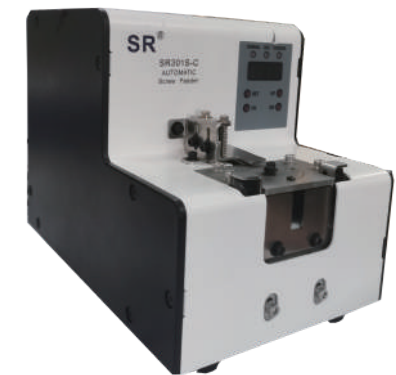

SR-728L-C供料器

SR-728L-C feeder

產品資訊

Product information

- ◆品牌型號: 728L-C數顯型/三來司
- ◆輸入電壓: AC220V
- ◆輸出速度: 60-180pcs/分鐘
- ◆定位精度: ± 0.02 mm
- ◆適用螺絲: M2.0-M6.0可調(牙長30)
- ◆螺絲分料方式: 滾動盤掃刷
- ◆附帶配件: 內六角扳手, 直流電源, 說明書
- ◆外形尺寸: 263*163*178 (寬長高)
- ◆整機重量: 4.5Kg

產品優勢與亮點分析

- 1、高精度, 伺服鎖付精準、使用壽命長、幾乎免維護、扭力大小可控;
- 2、不要在易燃和有腐蝕性氣體環境下操作此機器;
- 3、轉盤式, 送料, 配合自動化螺絲機設備使用, 效率極高;
- 4、軌道可調, 通過更換轉盤和導軌調整可適用M1.0~M5.0的螺絲, 螺絲長度可達15mm;
- 5、智能數顯, 機器帶有計數功能, 取走一顆螺絲自動計數下一顆;
- 6、性能穩, 關鍵部位採用高質量五金材料並經過特殊處理, 電子原器件採用原裝進口, 確保設備零故障。



螺絲供料器

Screw feeder

SR-a101C供料器

SR-a101C feeder

產品信息

product information

- ◆ 品牌型號：a101C數顯型/三來司
- ◆ 輸入電壓：AC220V
- ◆ 輸出速度：60-180pcs/分鐘
- ◆ 定位精度：±0.02 mm
- ◆ 適用螺絲：M1.0-M5.0可調
- ◆ 螺絲分料方式：滾動盤掃刷
- ◆ 附帶配件：起子頭，螺絲刀，靜電線，分料模組
- ◆ 外形尺寸：200.20*126*150.10 (寬長高)
- ◆ 整機重量：2Kg

產品優勢與亮點分析

- 1、專門排列短小螺絲，機器穩定自帶信號接線端子，方便信號通訊；
- 2、體積小，可配合產線作業，降低工人的勞動強度；
- 3、通用性強，更換螺絲輸送模組可適應 M 1.4- M 6的螺絲鎖付；
- 4、氣源動力，性能穩定，一天可持續24小時工作，壽命可達5-8年；
- 5、安裝此機器要在一個水準、穩定且能夠承受機器重量和運行條件的位置上安裝；
- 6、當機器在操作過程中發現有異常現象，譬如刺耳的聲音等，請立即停止機器運行，關掉電源開關，切斷電源適配器。



SR-SC15供料器

SR-SC15 feeder

產品信息

product information

- ◆ 品牌型號：SC15數顯型/三來司
- ◆ 輸入電壓：AC220V
- ◆ 輸出速度：60-180pcs/分鐘
- ◆ 定位精度：±0.02 mm
- ◆ 適用螺絲：M1.0-M5.0可調
- ◆ 螺絲分料方式：滾動盤掃刷
- ◆ 附帶配件：內六角扳手，直流電源，說明書
- ◆ 外形尺寸：172*126*150 (寬長高)
- ◆ 整機重量：2.6Kg

產品優勢與亮點分析

- 1、一機可適用多種規格螺絲，特殊螺絲，1:1短螺絲，帶墊片螺絲都可以通用；
- 2、不要在易燃和有腐蝕性氣體環境下操作此機器；
- 3、軌道式，送料，配合自電批使用；
- 4、軌道可調，通過更換轉盤和導軌調整可適用 M1.0~M5.0的螺絲，螺絲長度可達15mm；
- 5、智能數顯，機器帶有計數功能，取走一顆螺絲自動計數下一顆；
- 6、性能穩，關鍵部位採用高質量五金材料並經過特殊處理，電子原器件採用原裝進口，確保設備零故障。



無鉛智能焊台

Lead-free intelligent welding table

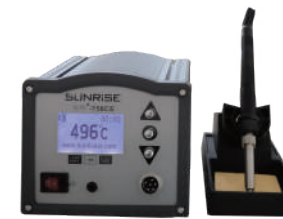

SR-750CE



SR-800焊台



SR-900焊台



SR-212焊台



SR-518焊台



SR-520焊台

產品名稱	SR-750	SR-800	SR-900	SR-212	SR-518	SR-520
最大輸入功率	75W	80W	90W	120W	180W	250W
溫度調節範圍	50—500°C		50—600°C			
輸入電壓	220V~110V					
輸出電壓	~36V					
最大環境溫度	40°C					
外殼材料	鋁合金					
外形體積	(145*125*95) (長寬高)					

額定電壓	~36v
烙鐵頭至接地電阻	低於2Ω
烙鐵頭至接地電勢	低於2mV
發熱元件	高頻渦流式
電線裝置	1.2m
手柄長度 (不含導線)	190mm
重量	105g

無鉛智能焊台

Lead-free intelligent welding table



SR-9800出錫機

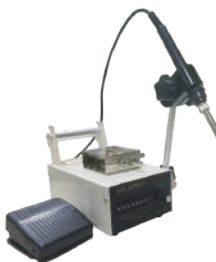

SR-375A出錫機

產品名稱	SR-375A	SR-9800	SR-HD200	SR-520TA
最大輸入功率	75W	90W	200W 一體式發熱	250W
適用手柄	SR-907	SR-9012	SR-200	SR-911G
溫度調節範圍	50—500°C		50—600°C	
輸入電壓	220V~110V			
輸出電壓	~36V			
最大環境溫度	40°C			
外殼材料	鋁合金			

型號	SR-520TA	SR-HD200/HD400
額定電壓	36VAc	24VAc/26.5VAc
烙鐵頭至接地阻值	低於2Ω	低於2Ω
烙鐵頭至接電電壓	低於2mV	低於2mV
發熱方式	高頻渦流式	電阻式
發熱件功率	150W	200W/400W
發熱元件	分體式	一體式
通訊方式	/	RS485



SR-520TA焊台



SR-HD200焊台

自動出錫機

Automatic tin dispenser



SR-單工站雙體焊錫機



SR-單工站焊錫機



SR-9120出錫機



SR-9120A破錫機



手動出錫



產品名稱	SR-單工站 焊錫機	SR-單工站 焊錫機	SR-9120	SR-9120A
最大輸入功率	250W	250W	120W	120W
適用手柄	SR-911/SR-911G (可選)		SR-520	SR-520
溫度調節範圍	50—500°C		50—600°C	
輸入電壓	220V~110V			
輸出電壓	~36V			
最大環境溫度	40°C			
外殼材料	鋁合金			

額定電壓	~36v
烙鐵頭至接地電阻	低於2Ω
烙鐵頭至接地電勢	低於2mV
發熱元件	高頻渦流式
電線裝置	1.2m
手柄長度 (不含導線)	190mm
重量	105g

百搭恆溫槍

Joker constant temperature gun

注意事項:

- ◆ 焊槍需配恆溫焊台使用，須預熱 10-20 秒鐘，有冒煙現象是屬正常的；
- ◆ 將焊錫線從進錫口插入，只要將板機方向向上推動，直到錫絲送到導錫管口止，就可以正常工作了；
- ◆ 在工作時，烙鐵咀和烙鐵管的溫度高達 400 度以上，嚴禁人體觸摸以免灼傷；
- ◆ 手焊槍停止使用時，請將它放在它的支架上；
- ◆ 工作完成後，關閉電源等完全冷卻後才能保存放置。



Note:

- ◆ The welding gun needs to be used with a constant temperature welding table, which must be preheated for 10-20 seconds, and the smoking phenomenon is normal;
- ◆ The solder wire is inserted through the tin inlet, as long as the direction of the plate is pushed upward until the tin wire reaches the mouth of the tin guide tube's working;
- ◆ When working, the temperature of the soldering iron tip and the soldering iron tube is up to 400 degrees or more, and it is strictly prohibited to touch the human body to avoid burns;
- ◆ When the torch is out of use, place it on its support;
- ◆ After the work is completed, turn off the power and completely cool before saving and placing.



SR-706 百搭出錫槍



SR-702 百搭出錫槍



SR-705 百搭出錫槍

使用方法:

- ◆ 停止使用時需退出或更換錫絲時，只要將板機方向向上推動（方法同上），同時取出錫絲。
- ◆ 更換發熱芯時，先把防護蓋拆下，再拆下烙鐵咀，就可以更換發熱芯了。

How to use:

- ◆ When you need to exit or replace the tin wire when you stop using it, just push the direction of the plate upward (the same method as above) and remove the tin wire at the same time.
- ◆ When replacing the heating core, first remove the protective cover, and then remove the soldering tip, you can replace the heating core.

產品名稱	SR-706	SR-702	SR-705
輸入功率	60W	80-120W	150-250W
焊台	SR-936	SR-800/900/120	SR-158/SR-520
發熱芯系列	A1321陶瓷	SR-520插拔式金屬	SR-58插拔式金屬
烙鐵頭	900系列	200系列	500系列
電源電壓	C220/50Hz		
溫度範圍	50-600°C		
接地電阻	≤2Ω		

無鉛焊台手柄

Lead-free welding table handle



SR-907手柄 SR-9012手柄 SR-520手柄 SR-A1321發熱芯 SR-9012發熱芯 SR-520發熱芯

產品名稱	SR-936	SR-750	SR-800	SR-900	SR-212	SR-518	SR-520
輸入功率	60W	75W	80W	90W	120W	180W	250W
烙鐵手柄	SR-907手柄	SR-9012/SR-520可選				SR-58手柄	
發熱芯系列	A1321發熱芯	SR-9012焊接式/SR-520插拔式可選				SR-58插拔式	
烙鐵頭	900系列	通用200系列				500系列	
電源電壓	C220/50Hz						
溫度範圍	50-600°C						
接地電阻	≤2Ω						



SR-58手柄 SR-911G手柄 SR-911手柄 SR-58發熱芯 SR-58M發熱芯

產品名稱	SR-520TA
輸入功率	250W
烙鐵手柄	SR-911/911G (可選)
發熱芯系列	SR-58帶定位插拔式
烙鐵頭	911/911G系列通用
電源電壓	C220/50HZ
溫度範圍	50-600°C
接地電阻	≤2Ω

無鉛焊台烙鐵頭

Lead-free table soldering iron tip

普通烙鐵頭

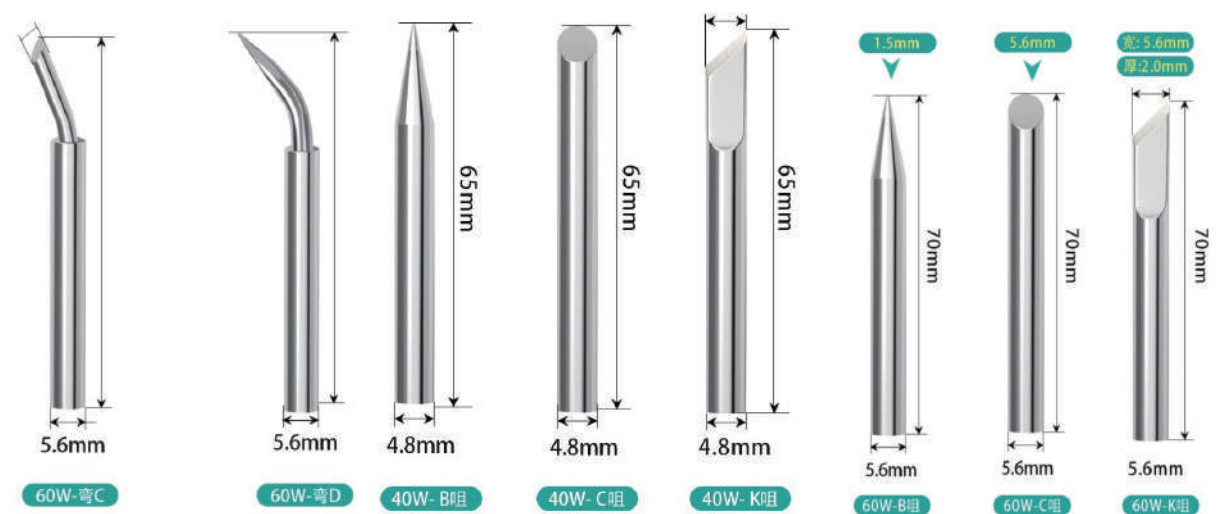
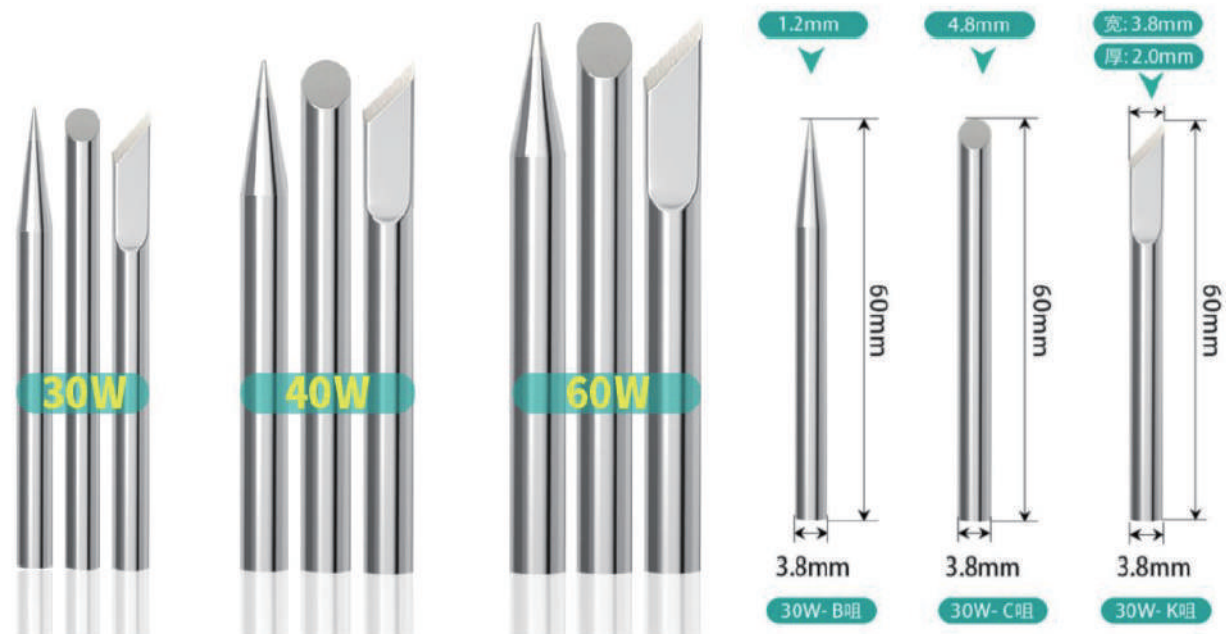

無鉛焊台烙鐵頭

Lead-free table soldering iron tip

900系列烙鐵頭

圆锥型B嘴/尖针型I嘴(可定制)



- ① 900M-T-特尖 ② 900M-T-IS尖弯 ③ 900M-T-S短尖
- ④ 900M-T-1.0B ⑤ 900M-T-B ⑥ 900M-T-2B
- ⑦ 900M-T-2CF ⑧ 900M-T-5B ⑨ 900M-T-S4
- ⑩ 900M-T-2CF ⑪ 900M-T-LB

扁头/一字起型D嘴(可定制)



- ① 900M-T-0.8D ② 900M-T-1.2D ③ 900M-T-1.6D
- ④ 900M-T-2.4D ⑤ 900M-T-3.2D ⑥ 900M-T-4.6D

斜口/马蹄型C嘴(可定制)



- ① 900M-T-0.8C ② 900M-T-1C ③ 900M-T-2C
- ④ 900M-T-3C ⑤ 900M-T-4C ⑥ 900M-T-5C
- ⑦ 900M-T-2CF ⑧ 900M-T-3CF ⑨ 900M-T-4CF

刀口型K嘴(可定制)



- ① 900M-T-短 ② 900M-K(打孔) ③ 900M-T-K
- ④ 900M-T-1.5K ⑤ 900M-T-SK ⑥ 900M-T-1.5SK
- ⑦ 900M-T-1.5LK

注: 不常用型号暂未拍照, 有需要可与客服了解详情

無鉛焊台烙鐵頭

Lead-free table soldering iron tip

200系列烙鐵頭

1 200-B

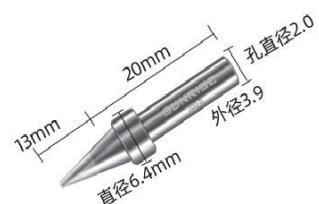

200-I (尖嘴)



刀口型K嘴 (可定制)



2 200-K

刀背厚度2.2-2.3mm



200-1.5

刀背厚度1.5-1.6mm

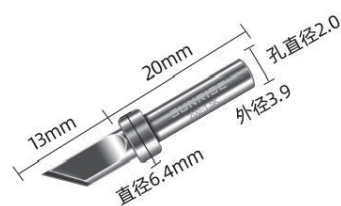

圓錐尖針型B咀 (可定制)

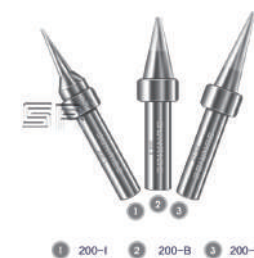

5 200-2C

刀背厚度2.2-2.3mm



200-3C

刀背厚度1.5-1.6mm



圓錐尖針型B咀 (可定制)

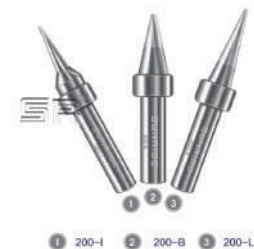

6 200-0.8D

刀背厚度2.2-2.3mm

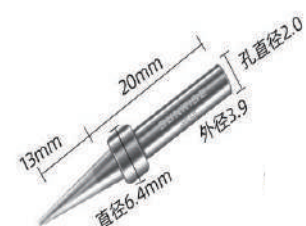

200-1.2D

刀背厚度1.5-1.6mm

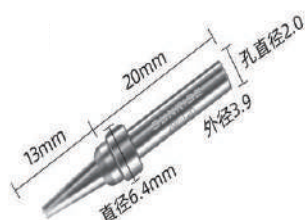

200系列烙鐵頭 (可定制)



500系列烙鐵頭

(可定制)



延長烙鐵頭壽命技巧

1. 少用助焊劑焊絲: 尤其是含鹵元素焊絲;
2. 設定最佳焊接溫度: 溫度越高, 烙鐵頭壽命越短;
3. 購置正規烙鐵頭: 便宜沒好貨, 好貨不便宜;
4. 規範化操作流程: 無規矩, 不成方圓;
5. 烙鐵頭常保養: 常清潔嘴頭。

* 500系列焊嘴適用於150w-250w高頻過流發熱焊台

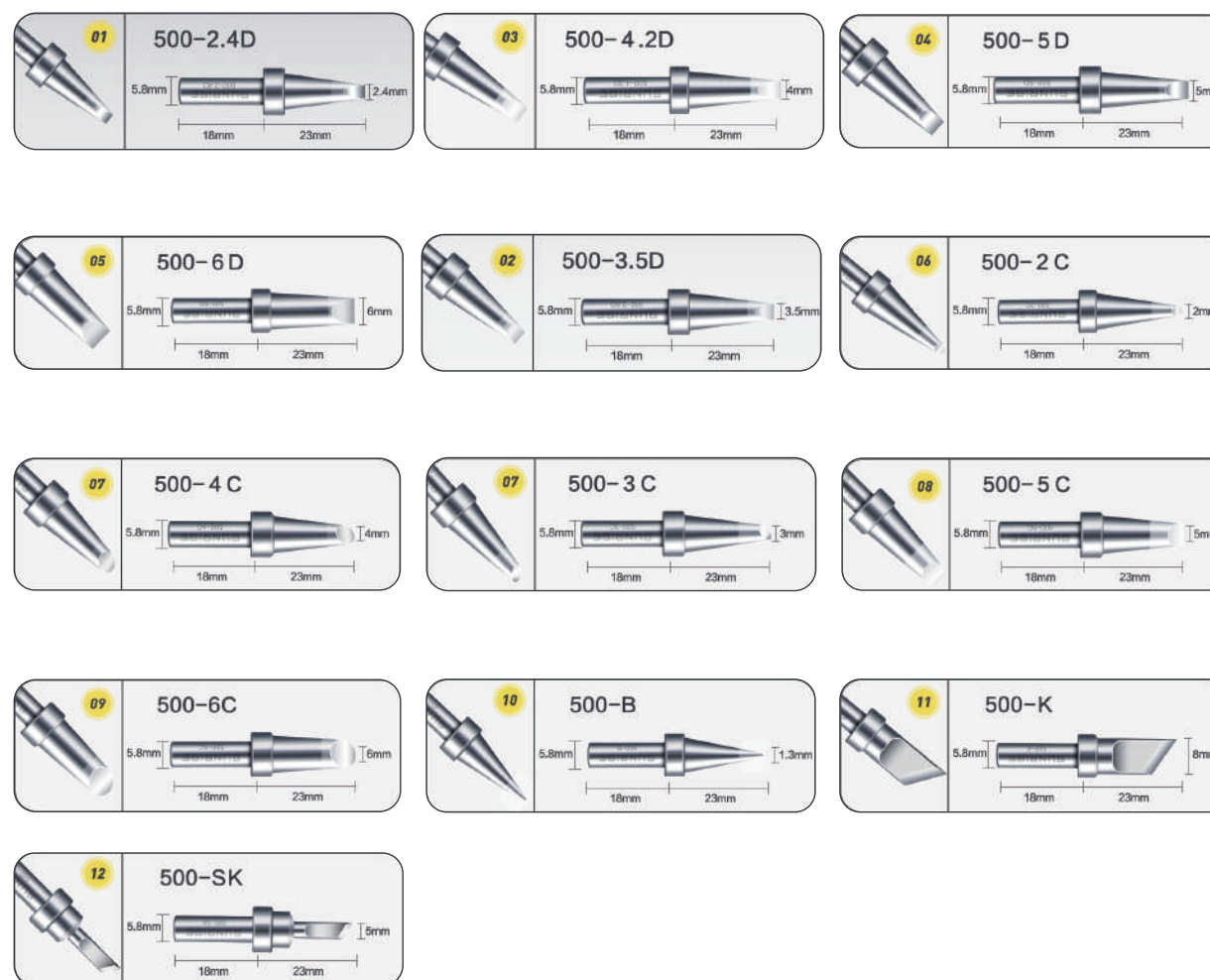

威樂烙鐵頭

Wille soldering iron head

多種頭咀型可選 D/DV1/DV2

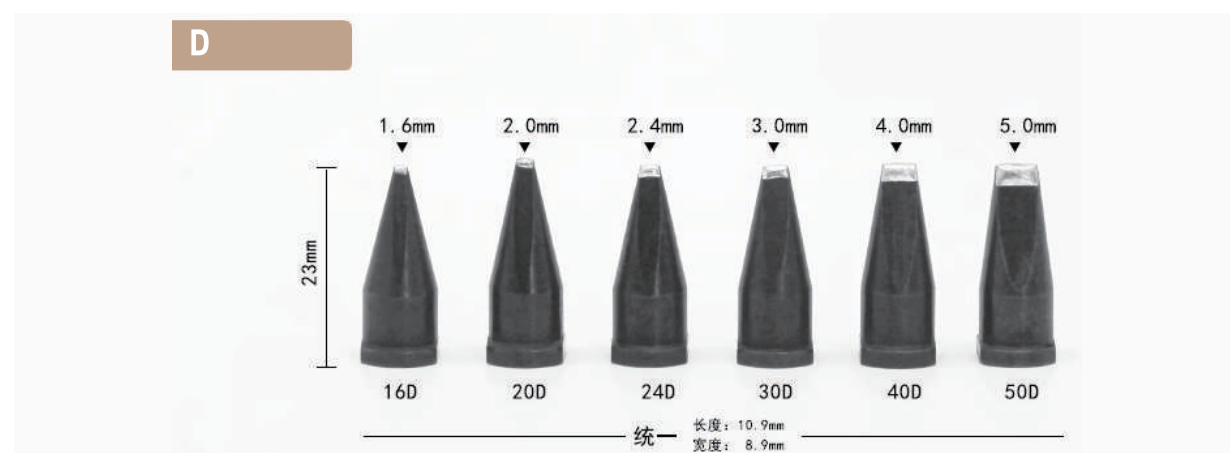
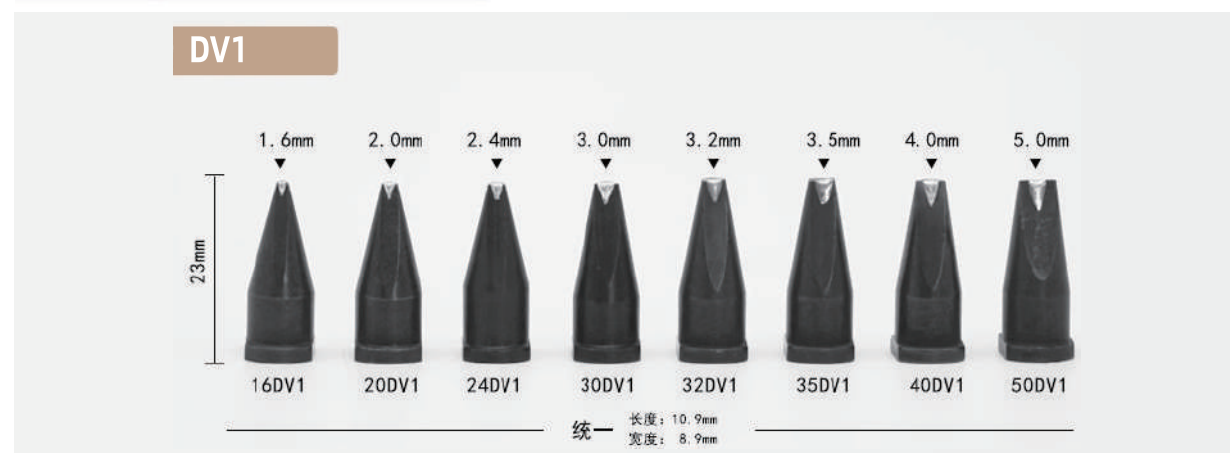
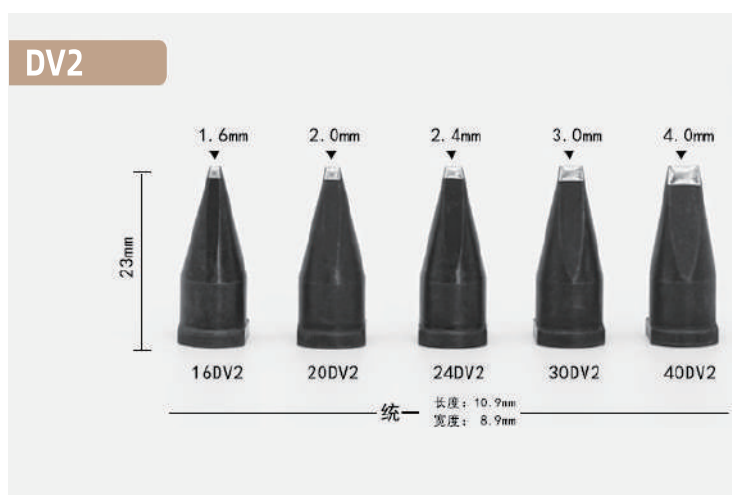

機用烙鐵頭

Machine soldering tip

911G烙鐵頭

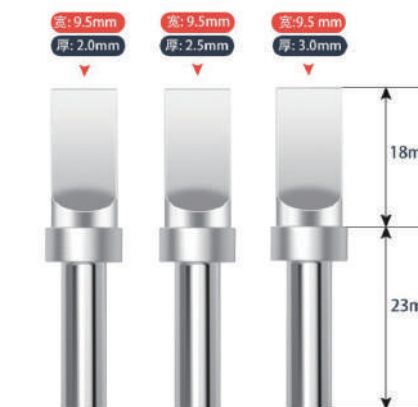
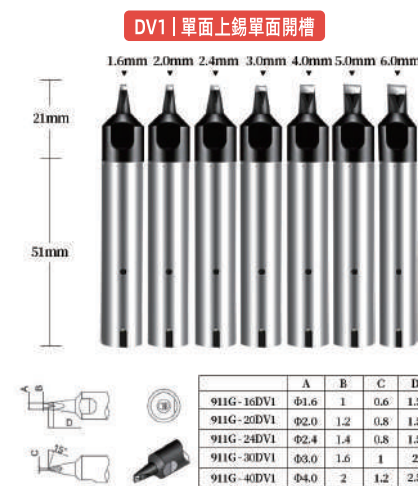

機用烙鐵頭

Machine soldering tip

911烙鐵頭

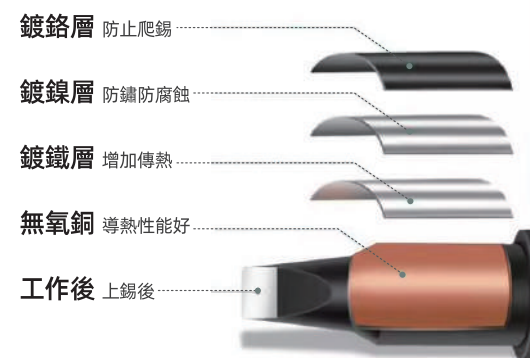

紫銅 —— 紫銅為主料，導熱性能卓越。
鐵 —— 起抗腐蝕的作用，是影響烙鐵頭使用壽命的關鍵因素。
鎳 —— 起到鍍鐵層防鏽的作用，而且便於後面鍍務。
鉻 —— 不粘錫，防止使用時錫往烙鐵頭身體上跑。烙鐵頭後部溫度一定比前部溫度低，所以鍍鉻有能防止爬錫。

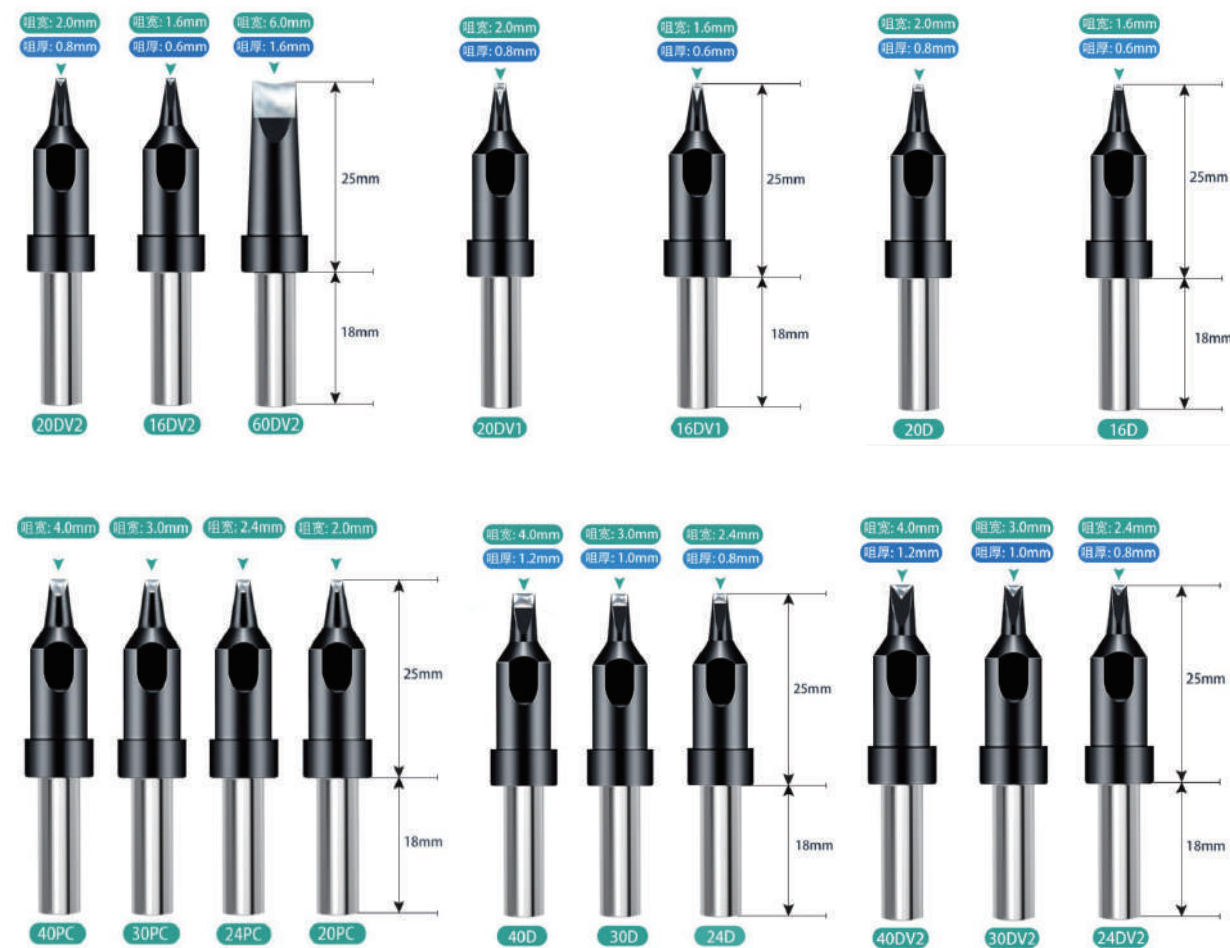

電阻式一體式插拔款

Resistive integrated plug out

C470系列 400W

470手柄通用型烙鐵頭一烙鐵頭發熱芯一體式設計
 可以根據產品定制不頭頭型

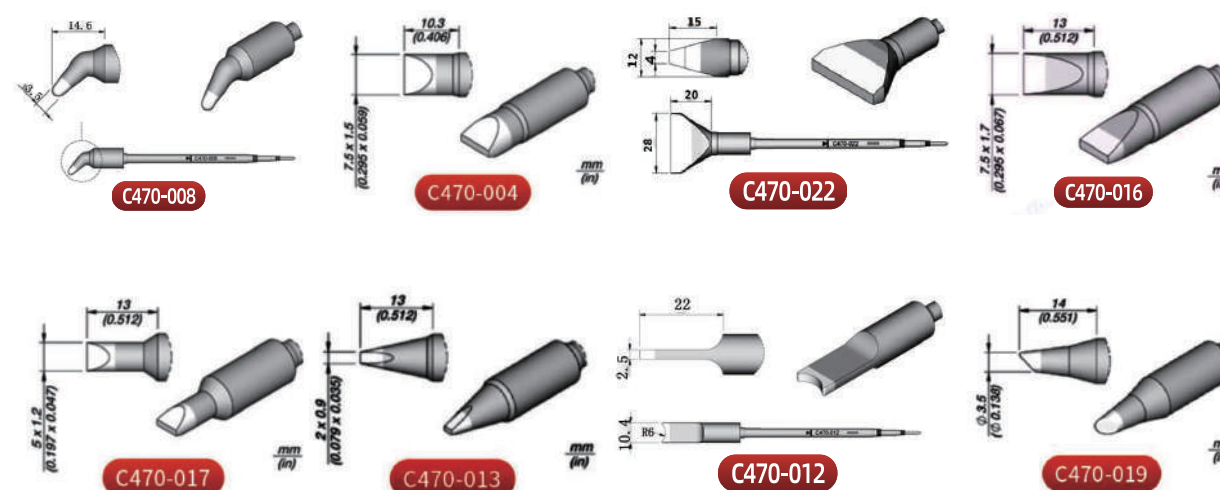
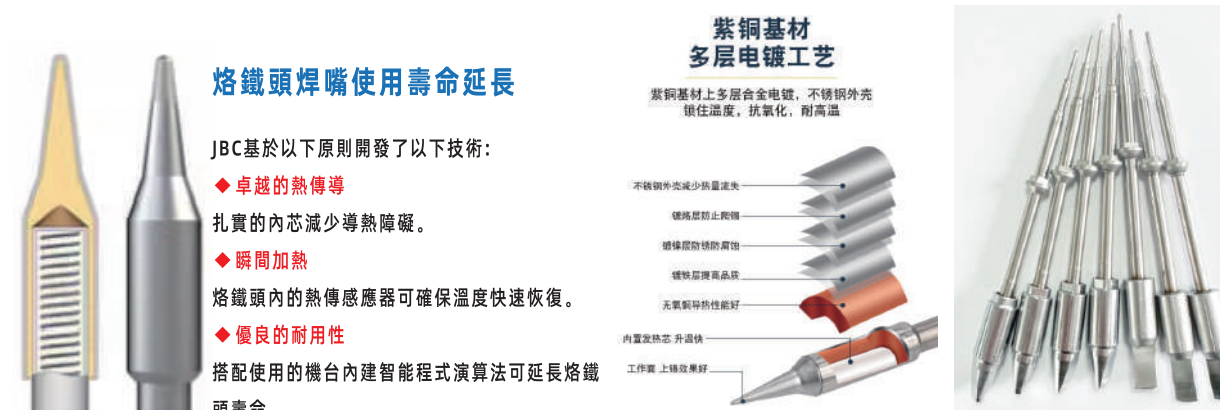

電阻式一體式插拔款

Resistive integrated plug out

C245系列 200W

C245 烙铁头介绍

注: C210烙铁头与C245烙铁头不能通用

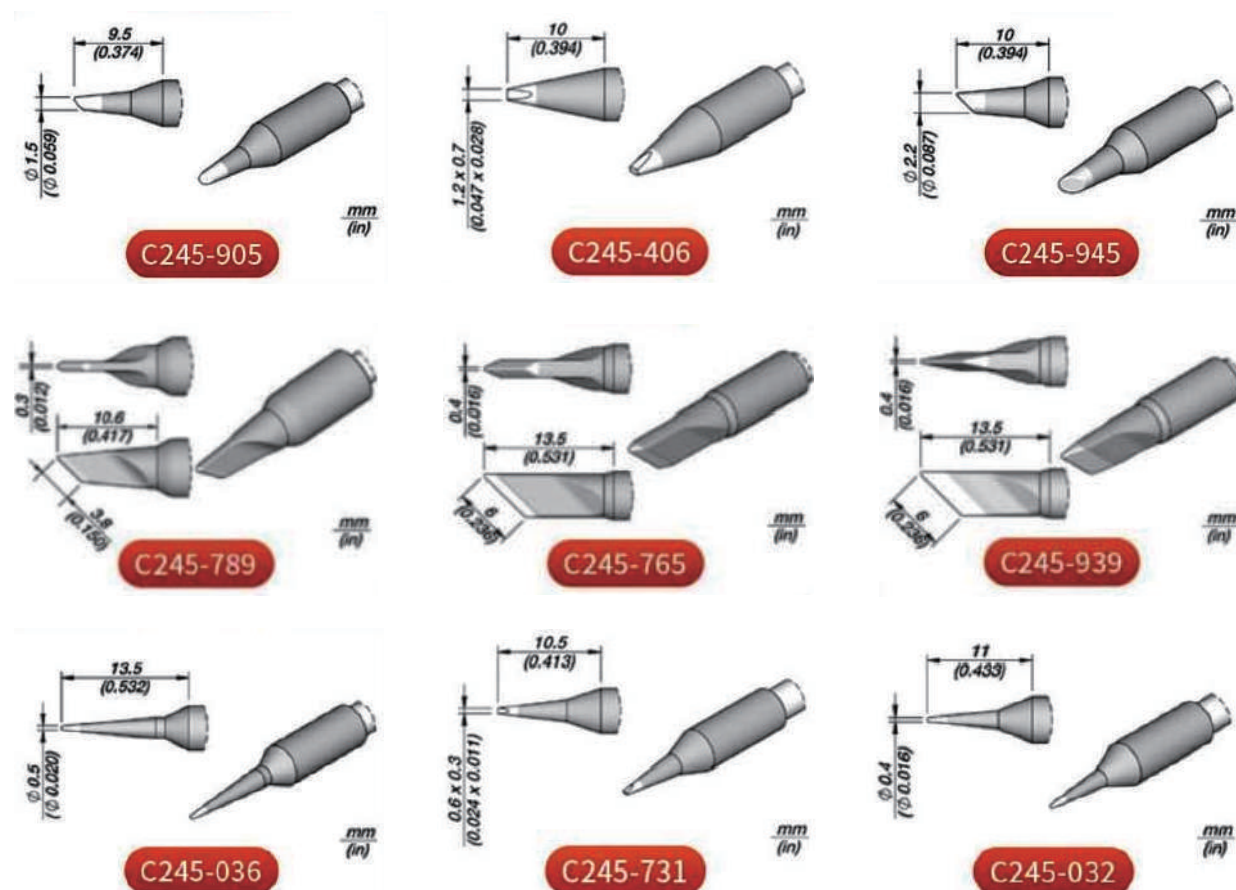

機用智能電批

Machine with intelligent electrical screw driver

產品描述

- 1、高精度扭力控制，扭力精度達到3%—5%；
- 2、採用高端進口馬達，產品壽命長，免維護精確的浮高/滑牙檢測，回饋給PLC或控制卡作異常處理；
- 3、支持多種任務管理編程，可滿足各種螺絲，扭矩要求快速自由切換，及自動切換；
- 4、精準的入牙檢測功能，保證擰緊信號的精確啟動；
- 5、鎖付結果可追溯、可導出、可上傳MES系統；
- 6、16種擰緊任務，每種任務支持5個擰緊步驟，拆卸任務支持2個拆卸步驟保證擰緊拆卸工藝高可控性；
- 7、支持RS232/485Modbus RTU通信協議擴展性強，支持多路IO輸入/輸出可非標定制TCP/IP網口，可快速構建智能鎖付系統安裝簡單，調試簡易，提供二次開發的介面和技術支持。

L型機用式智能電批

型号: SR-L-0220
 直流电压: 24-48V
 扭力范围: 0.3-2.0kgf.cm
 自动模式速度: 30-1200rpm
 高速模式速度: 30-1800rpm
 重量: 0.5kg
 扭力精度: ±5%

ML型機用式智能電批

型号: SR-ML-1040
 直流电压: 36-60V
 扭力范围: 1-4kgf.cm
 自动模式速度: 30-1200rpm
 高速模式速度: 30-1800rpm
 重量: 0.6kg
 扭力精度: ±5%

XL型機用式智能電批

型号: SR-XL-2580
 直流电压: 36-60V
 扭力范围: 2.5-8kgf.cm
 自动模式速度: 30-1200rpm
 高速模式速度: 30-1800rpm
 重量: 0.8kg
 扭力精度: ±5%

智能電批相關介紹



系統擴展架構圖

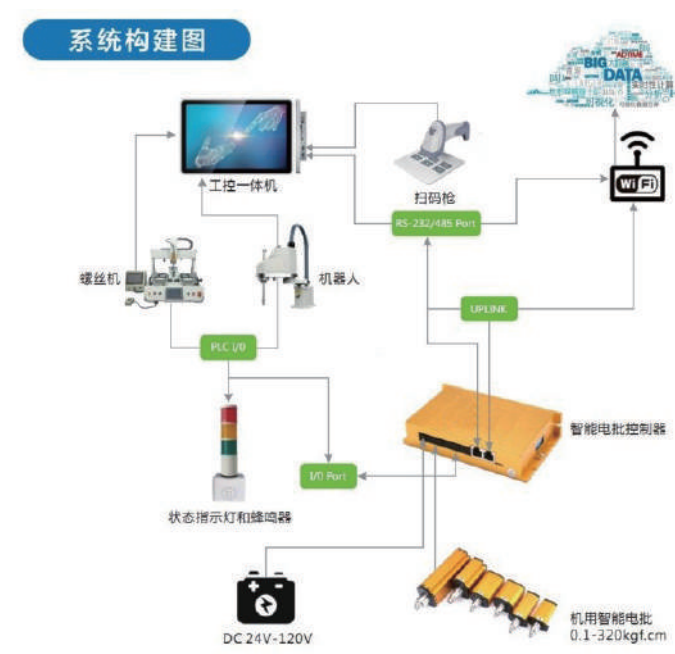

機用智能電批

Machine with intelligent electrical screw driver

智能機用選型表

機用式型號	適用扭力	速度(rpm)	重量(kg)	扭力精度	電壓(V)
SR-S-001	0.1-0.8(kgf.cm)	自動模式:30-1200	0.4	±5%	DC:24-48 建議24
	0.01-0.08(N.m)	高速模式:30-1800			
SR-L-001	0.3-2.0(kgf.cm)	自動模式:30-1200	0.5	±5%	DC:24-48 建議24
	0.03-0.2(N.m)	高速模式:30-1800			
SR-L-001-Z	0.3-1.8(kgf.cm)	自動模式:30-1200	0.6	±5%	DC:24-48 建議24
	0.03-0.18(N.m)	高速模式:30-1800			
SR-ML-001	1.0-4.0(kgf.cm)	自動模式:30-1200	0.6	±5%	DC:36-60 建議48
	0.1-0.4(N.m)	高速模式:30-1800			
SR-XL-001	2.5-8.0(kgf.cm)	自動模式:30-1200	0.8	±5%	DC:36-60 建議48
	0.25-0.8(N.m)	高速模式:30-1800			
SR-DXL-001	6.0-23.0(kgf.cm)	自動模式:30-1200	1.7	±5%	DC:80-120 AC:60-80 配DC 90
	0.6-2.3(N.m)	高速模式:30-1800			
SR-TXL-001	20.0-80.0(kgf.cm)	自動模式:30-600	2.3	±5%	DC:80-120 AC:60-80 配DC 90
	2.0-8.0(N.m)				
SR-TXL-002	50.0-150.0(kgf.cm)	自動模式:30-300	2.3	±5%	DC:80-120 AC:60-80 配DC 90
	5.0-15.0(N.m)				
SR-TXL-003	60.0-180.0(kgf.cm)	自動模式:30-300	2.3	±5%	DC:80-120 AC:60-80 配DC 90
	6.0-18.0(N.m)				
SR-TXL-004	20.0-60.0(kgf.cm)	自動模式:30-900	2.3	±5%	DC:80-120 AC:60-80 配DC 90
	2.0-6.0(N.m)				



- 1、支持各種扭矩要求，標準機用可滿足0.1kgf.cm-360kgf.cm；
- 2、支持各種扭矩要求，標準手持可滿足0.1kgf.cm-130kgf.cm；
- 3、支持定做更大的扭力要求，目前定做成功案例有1200kgf.cm；

- 1、support a variety of torque requirements, standard machine can meet 0.1kgf.cm-360kgf.cm;
- 2、support a variety of torque requirements, standard handheld can meet 0.1kgf.cm-130kgf.cm;
- 3、support the customization of greater torque requirements, the current customization of successful cases are 1200kgf.cm;

手持智能電批

Handheld smart battery

系統擴展架構圖



機用式型號	適用扭力	速度(rpm)	重量(kg)	扭力精度	電壓(V)
SR-HS-001	0.1-0.8(kgf.cm)	自動模式:30-1200	0.35	±5%	AC:220
	0.01-0.08(N.m)	高速模式:30-1800			
SR-HL-001	0.3-2.0(kgf.cm)	自動模式:30-1200	0.35	±5%	AC:220
	0.03-0.2(N.m)	高速模式:30-1800			
SR-HL-002	0.2-1.5(kgf.cm)	自動模式:30-2000	0.25	±5%	AC:220
	0.02-0.15(N.m)				
SR-HL-003	0.5-5.0(kgf.cm)	自動模式:30-2000	0.25	±5%	AC:220
	0.05-0.5(N.m)				
SR-HL-004	1.0-7.0(kgf.cm)	自動模式:30-1000	0.25	±5%	AC:220
	0.1-0.7(N.m)				
SR-HXL-001	1.5-8.0(kgf.cm)	自動模式:30-1000	0.45	±5%	AC:220
	0.15-0.8(N.m)	高速模式:30-1800			
SR-HXL-003	3.0-17.0(kgf.cm)	自動模式:30-2000	0.65	±5%	AC:220
	0.3-1.7(N.m)				
SR-HXL-003-W	3.0-13.0(kgf.cm)	自動模式:30-2000	0.81	±5%	AC:220
	0.3-1.3(N.m)				
SR-HXL-004	7.0-35.0(kgf.cm)	自動模式:30-1000	0.65	±5%	AC:220
	0.7-3.5(N.m)				
SR-HXL-004-W	7.0-28.0(kgf.cm)	自動模式:30-1000	0.81	±5%	AC:220
	0.7-2.8(N.m)				

公司一角

Corner of the company



旭升電子工具集團 (組織架構)

Sunrise Electronic Tools Group organizational structure
Sunrise Electronic Tools Group organizational structure

